

Regarding the FCC DTV Tuner Press Release dated August 8, 2002

Title: **FCC INTRODUCES PHASE-IN PLAN FOR DTV TUNERS**

One of the inputs the FCC relied upon was the report from Arthur D Little, Inc titled:  
**Assessment of the Impact of DTV on the Cost of Consumer Television Receivers**

I was the leader of this project on behalf of MSTV and NAB just prior to leaving ADL. The 100 page ADL report is on the FCC web site but since it is not so easy to find, I have made a copy of the report available on my website at

<http://www.lipoff.org>

The file is named dtv.pdf and includes:

- 1) A copy of the FCC press release
- 2) The transmittal letter from MSTV to the FCC as a cover letter to the report
- 3) The ADL report

I hope you find this report to be of interest.

--

Stu Lipoff

IP Action Partners

192 Kirkstall Road

Newton, Ma 02460

tel +1.617.244.3877

fax +1.617.249.0369

home +1.617.964.7577

cell +1.617.529.2125

pager 888.687.8524 or 6878524@skytel.com

web <http://www.ipaction.com>

psnl web <http://www.lipoff.org>



# NEWS

Federal Communications Commission  
445 12<sup>th</sup> Street, S.W.  
Washington, D. C. 20554

News media Information 202 / 418-0500  
Fax-On-Demand 202 / 418-2830  
TTY 202/418-2555  
Internet: <http://www.fcc.gov>  
<ftp.fcc.gov>

---

This is an unofficial announcement of Commission action. Release of the full text of a Commission order constitutes official action. See MCI v. FCC, 515 F 2d 385 (D.C. Circ 1974).

---

FOR IMMEDIATE RELEASE  
August 8, 2002

NEWS MEDIA CONTACTS:  
Michelle Russo 202-418-2358 (MB)  
Margo Davenport 202-418-2949 (MB)  
Lisa Gaisford 202-418-7280 (OET)

## **FCC INTRODUCES PHASE-IN PLAN FOR DTV TUNERS** *Plan Minimizes Costs and Allows Consumers to Access DTV Signals*

Washington, D.C. - Today, the Federal Communications Commission (FCC) adopted a plan that will give consumers access to digital programming over television by requiring off-air digital TV (DTV) tuners on nearly all new TV sets by 2007. By enacting a five-year rollout schedule that starts with larger, more expensive TV sets, the FCC is minimizing the costs for equipment manufacturers and consumers. This action marks another step in the FCC's progress toward making the digital television transition a reality.

The FCC said DTV receivers are a necessary element of broadcast television service in the same way that analog TV receivers have been since the inception of analog television service. Although analog receivers are still dominant today, that will change as the transition to digital TV progresses. The FCC said that its jurisdiction is established by the 1962 All Channel Receiver Act (ACRA), which provides the FCC with the "authority to require" that television sets "be capable of adequately receiving all frequencies" allocated by the FCC for "television broadcasting." The authority provided under the ACRA applies to all devices used to receive broadcast television service, not just those used to receive analog signals.

The FCC said the plan reflects and accounts for the following:

- including DTV reception capability in new television receivers will require the redesign of product lines,
- prices are declining and will decline even faster as economies of scale are achieved and production efficiencies are realized over time, and
- prices of large TV sets have been declining at a rate of \$100 to \$800 per year, so the additional cost of the DTV tuner may be partially or completely offset by the general price decline.

The FCC said this plan will ensure that new TV receivers include a DTV tuner on a schedule as close as economically feasible to the December 31, 2006, target completion date for the DTV transition that was set forth in the Communications Act by Congress.

- more -

The Second Report and Order and Second Memorandum Opinion and Order adopted today requires that all television receivers with screen sizes greater than 13 inches and all television receiving equipment, such as videocassette recorders (VCRs) and digital versatile disk (DVD) players/recorders, will be required to include DTV reception capability after July 1, 2007, according to the following schedule:

**Receivers with screen sizes 36 inches and above** -- 50% of a responsible party's units must include DTV tuners effective July 1, 2004; 100% of such units must include DTV tuners effective July 1, 2005.

**Receivers with screen sizes 25 to 35 inches** -- 50% of a responsible party's units must include DTV tuners effective July 1, 2005; 100% of such units must include DTV tuners effective July 1, 2006.

**Receivers with screen sizes 13 to 24 inches** -- 100% of all such units must include DTV tuners effective July 1, 2007.

**TV Interface Devices** VCRs and DVD players/recorders, etc. that receive broadcast television signals -- 100% of all such units must include DTV tuners effective July 1, 2007.

In the item today, the FCC also declined for the time being to adopt labeling requirements for TV receivers that are not able to receive any over-the-air broadcast signals. The FCC stated that it is unclear when, or if, such products will become commercially available or how they will be marketed. The FCC will continue to monitor the state of the marketplace and take additional steps if necessary to protect consumers' interests.

Today's item also amends the FCC rules to reference the most recent version of the Advanced Television System Committee's (ATSC) DTV standard. The FCC also stated that it will address the possible adoption of the ATSC's "Program System and Information Protocol" (PSIP) specification in its forthcoming Second Review of its policies for the DTV transition. In the interim, the FCC included the PSIP specification in its rules as a document that licensees may consult for guidance.

Finally, today's action denies a petition for reconsideration requesting that the FCC consider imposing minimum performance thresholds for DTV receivers. In reaffirming its previous decision on this issue, the FCC said that competitive forces are the best approach for ensuring that DTV receivers perform adequately and meet consumer needs in terms of price, quality, performance, and features.

-FCC-

MB Docket 00-39

Action by the Commission, August 8, 2002, by Second Report and Order and Second Memorandum Opinion and Order (FCC 02-230). Chairman Powell, Commissioners Abernathy and Copps, with Commissioner Martin dissenting and Chairman Powell, Commissioners Abernathy, Copps and Martin issuing statements.

Office of Engineering and Technology contact: Alan Stillwell, Associate Chief, (202) 418-2925

News about the Federal Communications Commission can also be found  
on the Commission's web site [www.fcc.gov](http://www.fcc.gov).

EX PARTE OR LATE FILED

ASSOCIATION FOR **MAXIMUM SERVICE TELEVISION, INC.**



November 8, 2001

Ms. Magalie Roman Salas  
Secretary  
Federal Communications Commission  
445 12<sup>th</sup> Street, SW, Suite B-204  
12<sup>th</sup> Street Lobby, Counter TW-A325  
Washington, DC 20554

RECEIVED

NOV 8 2001

FEDERAL COMMUNICATIONS COMMISSION  
OFFICE OF THE SECRETARY

1776 Massachusetts Ave. NW

Suite 310

Washington, DC 20036

Tel (202) 861-0344

Fax (202) 861-0342

vtawil@mstv.org

**Victor Tawil**  
Senior Vice President

**Re: Written Ex Parte Presentation: MM Docket No. 00-39  
(Review of the Commission's Rules and Policies Affecting the  
Conversion to Digital Television)**

Dear Ms. Salas:

Pursuant to Section 1.1206 (b)(1) of the Commission's rules, The Association for Maximum Service Television, Inc. (MSTV) hereby submits the attached report entitled "*Assessment of the Impact of DTV on the Cost of Consumer Television Receivers*" to be included as part of the record in MM Docket No. 00-39. The study was conducted by Arthur D. Little, Inc. for the Association for Maximum Service Television, Inc. and the National Association of Broadcasters.

Yours truly,

Victor Tawil

Cc: Michael Powell, Chairman, FCC  
Kathleen Abernathy, Commissioner, FCC  
Michael Copps, Commissioner, FCC  
Kevin Martin, Commissioner, FCC  
Kenneth Ferree, Bureau Chief, Cable Services Bureau, FCC  
Bruce Franca, Acting Chief, Office of Engineering & Technology, FCC  
Roy Steward, Chief, Mass Media Bureau, FCC  
Rick Chessen, Associate Chief, Mass Media Bureau, FCC  
Robert Pepper, Chief, Office of Plans and Policy, FCC

No. of Copies rec'd 011  
List ABCDE

# **Assessment of the Impact of DTV on the Cost of Consumer Television Receivers**

**Final Report to:**

**Maximum Service  
Television (MSTV) and  
National Association of  
Broadcasters (NAB)**

**September 10, 2001**

**Arthur D. Little, Inc.  
Cambridge, Massachusetts  
02140-2390 U.S.A.**

**Reference 74003**

## **Legal Notice**

*This report was prepared by Arthur D. Little, Inc. (ADL) for the Association for Maximum Service Television, Inc. (MSTV) and National Association of Broadcasters, Inc. (NAB), to develop an estimate of the direct material cost additions to enable reception of Advanced Television Systems Committee (ATSC) compatible broadcast transmissions. Neither ADL nor any person acting on its behalf:*

- *Makes any warranty, expressed or implied, with respect to the use of any information or methods disclosed in this report; or*
- *Assumes any liability with respect to the use of any information or methods disclosed in this report.*

# Table of Contents

|   |           |
|---|-----------|
| <b>LEGAL NOTICE.....</b>  | <b>I</b>  |
| <b>1 EXECUTIVE SUMMARY .....</b>                                    | <b>7</b>  |
| 1.1 INTRODUCTION.....   | 7         |
| 1.2 SCOPE AND METHODOLOGY.....                                      | 7         |
| 1.3 STUDY SCENARIOS .....   | 8         |
| 1.4 SUMMARY OF THE ANALYSIS .....                                   | 9         |
| 1.4.1 DTV Market Penetration.....                                   | 9         |
| 1.4.2 Manufacturing Learning Curve.....                             | 11        |
| 1.4.3 Sensitivity Analysis .....                                    | 12        |
| 1.4.4 Results of Cost/Price Analysis.....                           | 13        |
| 1.4.5 Key Uncertainties .....                                       | 16        |
| <b>2 INTRODUCTION.....</b>  | <b>18</b> |
| 2.1 REPORT ORGANIZATION .....                                       | 18        |
| 2.2 BACKGROUND.....   | 18        |
| 2.3 RELATED FCC RULEMAKING ACTIVITIES.....                          | 20        |
| 2.4 OVERVIEW OF DIGITAL TELEVISION TECHNOLOGY .....                 | 21        |
| 2.4.1 MPEG-2 Standard.....  | 24        |
| 2.4.2 Overview of ATSC Formats.....                                 | 24        |
| <b>3 SCOPE AND APPROACH.....</b>                                    | <b>26</b> |
| 3.1 SCOPE .....   | 26        |
| 3.1.1 Reference-model of Television Receiver .....                  | 26        |
| 3.1.2 Set-Top Transverter.....                                      | 27        |
| 3.1.3 TV Receivers vs. Set-top boxes .....                          | 28        |
| 3.2 APPROACH.....   | 30        |
| 3.2.1 Methodology Overview.....                                     | 30        |
| 3.2.2 Details of Methodology.....                                   | 32        |
| <b>4 KEY ASSUMPTIONS AND DATA SOURCES.....</b>                      | <b>34</b> |
| 4.1 KEY DATA RESOURCES .....  | 34        |
| 4.1.1 Estimates of Digital TV Sales.....                            | 36        |
| 4.1.2 Retail Prices on existing DTV products and Set-top Boxes..... | 39        |
| 4.1.3 Cost Information .....  | 42        |
| 4.1.4 Size Distribution of TV Sales.....                            | 44        |
| 4.1.5 Market Adoption of Related Products.....                      | 46        |
| 4.1.6 Typical Pricing of Conventional Television Receivers .....    | 49        |
| 4.1.7 Typical Retail Markups for Television Receivers .....         | 50        |
| 4.1.8 Interview Program.....  | 51        |
| 4.2 KEY ASSUMPTIONS.....  | 53        |
| <b>5 COST ANALYSIS.....</b>   | <b>56</b> |
| 5.1 SCOPE OF ANALYSIS .....   | 56        |
| 5.2 ANALYSIS AND METHODOLOGY .....                                  | 57        |
| 5.2.1 Bass Adoption Theory.....                                     | 57        |
| 5.2.2 Learning Curve Theory.....                                    | 59        |
| 5.3 INTEGRATED LEADER MODEL DTV .....                               | 60        |
| 5.3.1 Baseline Scenario: Free Market Adoption.....                  | 60        |
| 5.3.2 Sensitivity Analysis .....                                    | 65        |
| 5.3.3 Summary of Baseline Analysis.....                             | 71        |

|           |  |           |
|-----------|--|-----------|
| 5.3.4     | <i>Mandate Scenario</i> .....                    | 72        |
| 5.3.5     | <i>Phased-Mandate Scenario</i> .....             | 75        |
| 5.4       | INTEGRATED HIGHEND MODEL DTV.....                | 77        |
| 5.5       | SET-TOP BOX.....                                 | 79        |
| 5.5.1     | <i>Market Projection for Transverters</i> .....  | 79        |
| 5.5.2     | <i>Digital Satellite Set top box costs</i> ..... | 80        |
| 5.5.3     | <i>Set top box costs</i> .....                   | 80        |
| <b>6</b>  | <b>CONCLUSIONS</b> .....                         | <b>83</b> |
| 6.1       | SUMMARY OF RESULTS.....                          | 83        |
| 6.2       | DTV MARKET PENETRATION .....                     | 86        |
| 6.3       | MANUFACTURING LEARNING CURVE.....                | 87        |
| 6.4       | SUMMARY OF COST/PRICE ANALYSIS.....              | 87        |
| 6.4.1     | <i>SDTV Receivers</i> .....                      | 87        |
| 6.4.2     | <i>Set-top Transverter</i> .....                 | 90        |
| 6.5       | MAJOR UNCERTAINTIES.....                         | 90        |
| <b>7</b>  | <b>REFERENCES</b> .....                          | <b>92</b> |
|           | <b>APPENDICES</b> .....                          | <b>96</b> |
| <b>A.</b> | <b>SUPPORTING DATA</b> .....                     | <b>97</b> |



## List of Figures

|  |    |
|--|----|
| FIGURE 1-1 ESTIMATED DTV CUMULATIVE SALES UNDER STUDY SCENARIOS .....  | 9  |
| FIGURE 1-2 ESTIMATED DTV MARKET PENETRATION RATES UNDER STUDY SCENARIOS.....                                     | 10 |
| FIGURE 1-3 INCREMENTAL COST CURVES UNDER STUDY SCENARIOS.....  | 12 |
| FIGURE 1-4 SDTV SET-TOP BOX TRANSVERTER COST/PRICE ANALYSIS.....   | 16 |
| FIGURE 2-1 ALTERNATIVE DTV TRANSMISSION AND RECEPTION APPROACHES .....   | 23 |
| FIGURE 2-2 ATSC DIGITAL TELEVISION FORMATS.....  | 25 |
| FIGURE 3-1 SUMMARY OF STUDY CASES .....  | 27 |
| FIGURE 3-2 SIMPLIFIED BLOCK DIAGRAM OF LEADER MODEL NTSC ANALOG TV RECEIVER .....                                | 28 |
| FIGURE 3-3 SIMPLIFIED BLOCK DIAGRAM OF SDTV RECEIVER.....  | 28 |
| FIGURE 3-4 DTV TRANSVERTER SET-TOP BOX FOR DTV RECEPTION ON CONVENTIONAL ANALOG<br>NTSC TV RECEIVER.....         | 30 |
| FIGURE 3-5 ANALYSIS APPROACH AND METHODOLOGY OVERVIEW.....   | 32 |
| FIGURE 4-1 PROJECTED SALES OF DIGITAL TELEVISION RECEIVERS AND DISPLAYS.....                                     | 36 |
| FIGURE 4-2 U.S. HDTV PRODUCT SHIPMENTS .....   | 37 |
| FIGURE 4-3 U.S. DTV SALES .....  | 38 |
| FIGURE 4-4 US DIGITAL TV SUBSCRIBER FORECAST.....  | 38 |
| FIGURE 4-5 HISTORICAL SALES OF COLOR TV RECEIVERS SALES .....  | 46 |
| FIGURE 4-6 HISTORICAL SALES OF VIDEOCASSETTE RECORDERS (VCR).....  | 47 |
| FIGURE 4-7 U.S. DIRECT BROADCAST SATELLITE (DBS) SUBSCRIBERS .....   | 48 |
| FIGURE 4-8 HISTORICAL SALES OF PERSONAL COMPUTERS.....   | 49 |
| FIGURE 5-1 ANALYSIS AND METHODOLOGY OVERVIEW .....   | 57 |
| FIGURE 5-2 ESTIMATED DTV ADOPTION CURVE .....  | 59 |
| FIGURE 5-3 ESTIMATED COMPONENT COST LEARNING CURVE (PERCENT - BASELINE SCENARIO).....                            | 60 |
| FIGURE 5-4 BASELINE U.S. SALES FORECAST FOR DTV.....   | 61 |
| FIGURE 5-5 ASSUMED COST LEARNING CURVE FOR COMPONENTS (COST – BASELINE SCENARIO)<br>.....                        | 62 |
| FIGURE 5-6 BASELINE DTV SALES FORECAST AND COST LEARNING CURVE.....  | 63 |
| FIGURE 5-7 ESTIMATED IMPACT ON MANUFACTURER AND RETAIL PRICE.....  | 64 |
| FIGURE 5-8 ESTIMATED IMPACT ON MANUFACTURER AND RETAIL PRICE ASSUMING 1-YEAR<br>FORWARD PRICING .....            | 65 |
| FIGURE 5-9 DTV SALES AND MARKET SHARE FORECAST UNDER 30 MILLION V.S. 25 MILLION<br>ANNUAL TV SALES IN 2000.....  | 66 |
| FIGURE 5-10 ESTIMATED ADOPTION OF DTV VERSUS ASSUMED GROWTH RATE SCENARIO .....                                  | 67 |
| FIGURE 5-11 PROJECTED CUMULATIVE SALES VERSUS GROWTH RATE.....   | 68 |
| FIGURE 5-12 PROJECTED UNIT COST VERSUS ASSUMED INITIAL INCREMENTAL COST.....                                     | 69 |
| FIGURE 5-13 ESTIMATED IMPACT ON INCREMENTAL MANUFACTURER'S PRICE VERSUS ASSUMED<br>INITIAL INCREMENTAL COST..... | 70 |
| FIGURE 5-14 ESTIMATED IMPACT ON RETAIL PRICE VERSUS ASSUMED INCREMENTAL COST.....                                | 70 |

|   |    |
|---|----|
| FIGURE 5-15 BASELINE CASE RETAIL PRICE INCREASE PERCENTAGE .....                                    | 71 |
| FIGURE 5-16 PROJECTED UNIT SALES UNDER GOVERNMENT MANDATE SCENARIO.....                             | 73 |
| FIGURE 5-17 ESTIMATED IMPACT ON COST AND PRICE UNDER FCC MANDATE SCENARIO.....                      | 73 |
| FIGURE 5-18 ESTIMATED DTV ADOPTION UNDER MANDATORY PHASED SCENARIO.....                             | 75 |
| FIGURE 5-19 ESTIMATED COST AND PRICE IMPACT UNDER MANDATORY PHASED SCENARIO.....                    | 76 |
| FIGURE 5-20 COMMON COMPONENTS ACROSS DTV PRODUCTS .....   | 81 |
| FIGURE 6-1 ESTIMATED DTV CUMULATIVE SALES UNDER STUDY SCENARIOS .....                               | 83 |
| FIGURE 6-2 DTV MARKET PENETRATION RATE UNDER STUDY SCENARIO.....                                    | 84 |
| FIGURE 6-3 BASS ADOPTION BASELINE CASE FORECAST AND CEA FORECAST DTV PENETRATION<br>COMPARISON..... | 85 |
| FIGURE 6-4 INCREMENTAL COST IMPACT UNDER STUDY SCENARIOS.....                                       | 86 |
| FIGURE 6-5 SDTV RECEIVER COST/PRICE ANALYSIS .....  | 89 |

## List of Tables

|   |    |
|---|----|
| TABLE 4-1 REPRESENTATIVE INFORMATION SOURCES APPLIED IN ANALYSIS .....        | 35 |
| TABLE 4-2 SUMMARY OF DTV SALES (MILLION UNITS) .....                          | 39 |
| TABLE 4-3 SUGGESTED RETAIL PRICES OF DIGITAL TV SET-TOP DECODERS .....        | 40 |
| TABLE 4-4 SUMMARY OF THOMSON INCREMENTAL MANUFACTURING COST ESTIMATES .....   | 42 |
| TABLE 4-5 REPRESENTATIVE DTV COMPONENTS .....                                 | 43 |
| TABLE 4-6 DISTRIBUTIONS OF U.S. COLOR TV SALES BY SCREENSIZE (1999-2004)..... | 45 |
| TABLE 4-7 REPRESENTATIVE PRICING OF CONVENTIONAL COLOR TV RECEIVERS.....      | 50 |
| TABLE 5-1 SUMMARY OF RESULTS FOR BASELINE SCENARIO .....                      | 72 |
| TABLE 5-2 SUMMARY OF RESULTS FOR FCC MANDATE SCENARIO .....                   | 74 |
| TABLE 5-3 SUMMARY OF RESULTS FOR FCC PHASED MANDATE SCENARIO .....            | 77 |
| TABLE A-1 U.S. SALES OF DIGITAL TV SETS AND DISPLAYS TO DEALERS .....         | 97 |
| TABLE A-2 U.S. HDTV PRODUCT SHIPMENTS .....                                   | 97 |
| TABLE A-3 U.S. DTV RECEIVER SALES FORECAST .....                              | 97 |
| TABLE A-4 U. S. DIGITAL TV SUBSCRIBERS .....                                  | 97 |
| TABLE A-5 U.S. VCR SALES .....  | 97 |
| TABLE A-6 SALES OF COLOR TV RECEIVERS .....                                   | 98 |
| TABLE A-7 U.S. DIRECT BROADCAST SATELLITE SUBSCRIBERS.....                    | 98 |
| TABLE A-8 U.S. SALES OF PERSONAL COMPUTERS.....                               | 98 |
| TABLE A-9 AVERAGE PRICE OF U.S. ANALOG/DIGITAL TV SET-TOP RECEIVERS .....     | 99 |

# **1 Executive Summary**

## ***1.1 Introduction***

Arthur D. Little, Inc. (ADL) was commissioned by the Association for Maximum Service Television, Inc. (MSTV) and the National Association of Broadcasters (NAB) [MSTV, NAB] to develop cost estimates and estimates of the cost decline overtime for the incremental direct material required to enable consumer electronics television (TV) sets to receive over the air ATSC digital TV transmissions. This report also estimates the effect of these incremental costs on the retail prices for DTV sets. Also included are estimates of costs and retail prices for stand-alone set-top box “transverters” that can transcode ATSC transmissions to NTSC compatible signals, allowing existing analog TVs to receive ATSC signals.

## ***1.2 Scope and Methodology***

This project applies standard engineering and business analysis methods to publicly available information and the non-proprietary knowledge base of ADL staff, NAB staff, and MSTV staff. Additionally, interviews have been conducted with selected industry participants having knowledge or opinions that are relevant to this analysis, to supplement available information and validate key assumptions.

Three distinct market adoption scenarios for DTV receiver implementation were developed, which are explained in Section 1.3. For each scenario, estimates were made for overall sales and incremental material costs. The rate of market adoption and reduction in cost due to production volume were factored and used to predict the incremental cost of adding a DTV receiver to a new TV set at the time of manufacturing. Both manufacturing cost and retail price of the integrated DTV set is estimated.

To project the rate of adoption of integrated DTV receivers, Bass diffusion approach was utilized. The Bass approach is a widely applied and accepted model for the adoption (diffusion) of new products and technology by consumers.

The cost reduction of related semiconductors, which are a major cost factor in the DTV receiver, was estimated over time by applying the effects of a manufacturing “Learning Curve”. The latter is based on industry historical experience in which prices decline with increasing, cumulative production volume.

Finally, the effects of a “Forward Pricing” policy [Japan High Tech Review, 1990] are examined in a sensitivity analysis. Forward pricing is a new-product introduction strategy commonly employed in the semiconductor industry.

These methodologies will be described in greater detail in Section 5 of this report, “Cost Analysis”.

In performing this analysis, we have made a number of key assumptions regarding the market and regulations. Section 4.2 provides more details on the “Key Assumptions”.

### **1.3 Study Scenarios**

Three DTV adoption scenarios have been defined for this study. Although the proposed FCC actions have not been finalized, it is believed that these options are within the range of possibilities currently under consideration.

- **Baseline Scenario:** This scenario assumes that Digital TV adoption is driven solely by natural market forces whereby a consumers’ purchase decision is based entirely on the benefits of a DTV receiver relative to the additional cost;
- **Mandate Scenario:** This scenario assumes that the government institutes a mandate requiring inclusion of a DTV receiver in all sets sold [manufactured] subsequent to a specified future date:
  - Institution of a government mandate that all TV sets 13 inches and above sold after January 1, 2004 should have the capability of receiving digital television;
  - January 1, 2004 is assumed the cut-off date based on the FCC’s proposed DTV transition rule which states that, by May 1, 2002, all commercial television stations must commence digital service, and all non-commercial television stations must begin [digital transmission] by May 1, 2003 [FCC, 1997; 47 CFR, 2000]. Under these assumptions, by January 1, 2004, most households should have the ability to access digital television content.
- **Phased Mandate Scenario:** This scenario assumes that the government institutes a phased mandate whereby initially more sophisticated, high end receivers would be required to include a DTV receiver and, over time, the requirement would be extended to include lower end models:
  - Effective in 2003, all TV sets manufactured with screen sizes 32 inches and above (approximately 19% of total TV sales) must have the capability of receiving digital television;
  - Effective in 2004, all sets with screen sizes 25 inches and larger (summed at approximately 56% of total TV sales); must have the capability of receiving digital television;
  - Effective in 2005, all sets having screen sizes 19 inches or above (summed at approximately 85% of total TV sales) must have the capability of receiving digital television; and
  - Effective in 2006, all TV sets must have the capability of receiving digital television;
  - This phased mandate scenario is based on the FCC’s proposed approach in its *Report and Order and Further Notice of Proposed Rule Making in the Matter of Review of the*

*Commission's Rules and Policies Affecting the Conversion To Digital Television:* "One approach to minimize the impact of such a requirement would be to phase it in over time to take advantage of declining costs associated with electronics manufacturing volumes and apply the requirement initially only to receivers with large screen sizes, e.g. 32 inches and above" [FCC, 2001c].

## 1.4 Summary of the Analysis

### 1.4.1 DTV Market Penetration

Our analysis of DTV penetration is based on the Bass Adoption model utilizing adoption factors from historic adoption of color television. The major findings are shown in Figure 1-1 and Figure 1-2, and summarized below:

**Figure 1-1 Estimated DTV Cumulative Sales Under Study Scenarios**

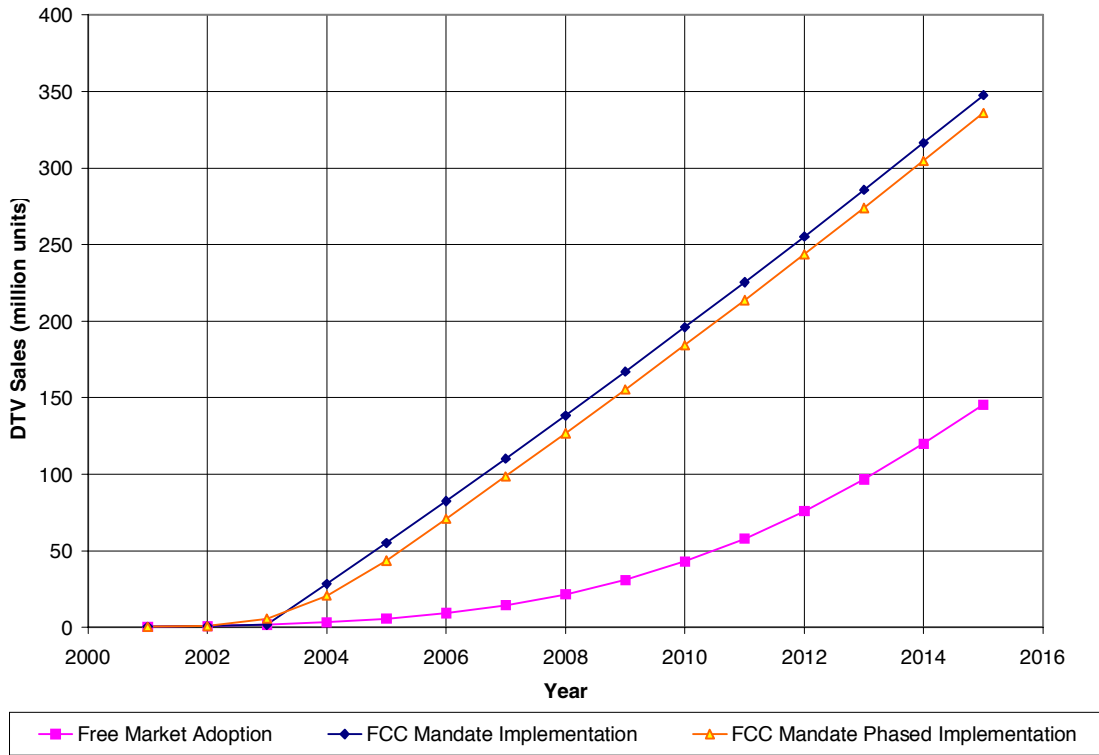

**Figure 1-2 Estimated DTV Market Penetration Rates Under Study Scenarios**

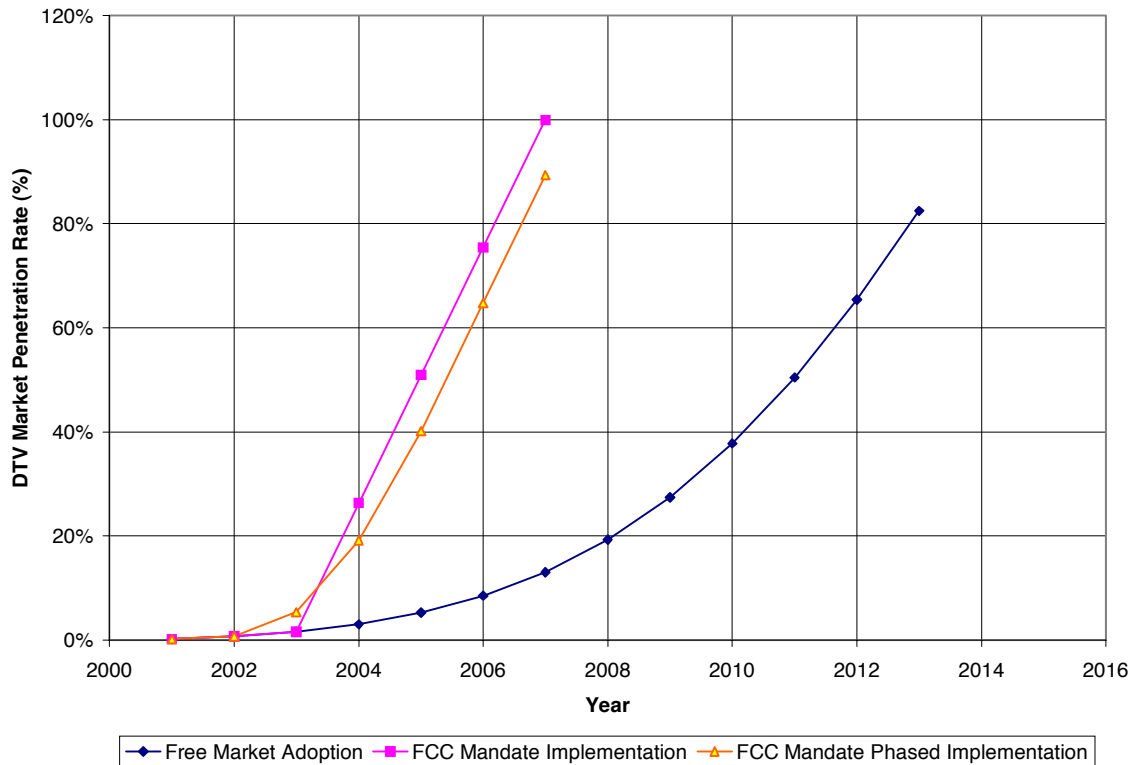

- **Free Market Adoption Scenario** - Assuming free market adoption of integrated DTV sets without governmental influence, we project that cumulative DTV sales will grow to approximately 9.3 million units by 2006. The corresponding penetration is projected to reach only 8.5% by 2006 (assuming 109.3 million TV households [Carmel Group, 2001a] in 2006, and each DTV sale represents a new adopting household). This is well below the FCC target of 85% by 2006 and, based on this projection, the 85% target penetration will not be reached until 2014 or later under this baseline scenario.
- **FCC Mandate Scenario** - Assuming the FCC were to institute a full government mandate beginning 2004, we project that cumulative DTV sales will be substantially higher relative to the baseline scenario. According to our projections, DTV sales would grow to approximately 82.5 million units by 2006, implying that 75.5% of US households would have DTV reception capability by 2006. The FCC target of 85% penetration could be reached in 2007 under this scenario.
- **Phased Mandate Scenario** - Assuming the FCC were to institute a phased mandate beginning in 2003, cumulative DTV sales are projected to reach approximately 71 million by 2006, with a corresponding 65% DTV penetration. The 85% FCC target penetration rate could be reached in 2007 under this scenario.

We have compared DTV market penetration projections under our Bass Adoption baseline scenario with the adjusted forecast numbers from CEA [CEA, 2001a] for the 6 years from 2001 to 2006. We obtained the CEA adjusted integrated DTV sales forecast by applying 20% on the CEA projected DTV sets and display sales (Note: Twenty-percent (20%) is the ratio of the integrated DTV sales over the total CEA forecasted DTV sets and display sales numbers. [CEA, 2001d]). Our projections are in line with those from the CEA especially in initial 3 years with the CEA adjusted forecasts a little bit higher. Since 2003, ours projection exceeds the CEA adjusted projection ending with 2.6 million sets higher in 2006. The major discrepancies of these two forecasts may lie in different forecast methodologies and the assumptions applied.

### ***1.4.2 Manufacturing Learning Curve***

The analysis also considers the impact of the manufacturing “Learning Curve” on the incremental manufacturing cost to add DTV receivers to television sets as well as the incremental retail price to consumers. This assumes that, as the cumulative number of manufactured units’ increases, the manufacturing cost falls exponentially due to the availability of integrated components and improvements in manufacturing processes. Refer to Section 5.2.2, “Learning Curve Theory” for more details.

Under all scenarios, we assume that the initial, incremental material cost will be approximately \$100 per set in 2001. Adjusted for typical manufacturing and retail markups, this corresponds to approximately a \$180 initial retail price increase to the consumer for a ‘leader’ model television set. The incremental cost impact over time under each of the scenarios considered is summarized as follows and shown in Figure 1-3. The same DTV market penetration rates comparison is shown in Figure 1-2.

Specifically:

- Under the free market adoption (baseline) scenario, the incremental material cost to incorporate a DTV receiver is projected to decrease from \$100 to approximately \$21 by the year 2006. Adjusted to reflect typical manufacturing and retail markups, the incremental price to consumers is projected to decrease from \$180 to \$38 by 2006.
- Under the full mandate scenario, the incremental material cost is projected to decrease more rapidly due to increased DTV sales beyond 2004. The \$100 incremental material cost is projected to decrease to approximately \$8.40 by 2006, which corresponds to a projected retail price increase of approximately \$15.
- Under the phased mandate scenario, the incremental material cost is projected to decrease from \$100 initially to \$9 by 2006. The corresponding incremental retail price is estimated to be \$16.



**Figure 1-3 Incremental Cost Curves under Study Scenarios**

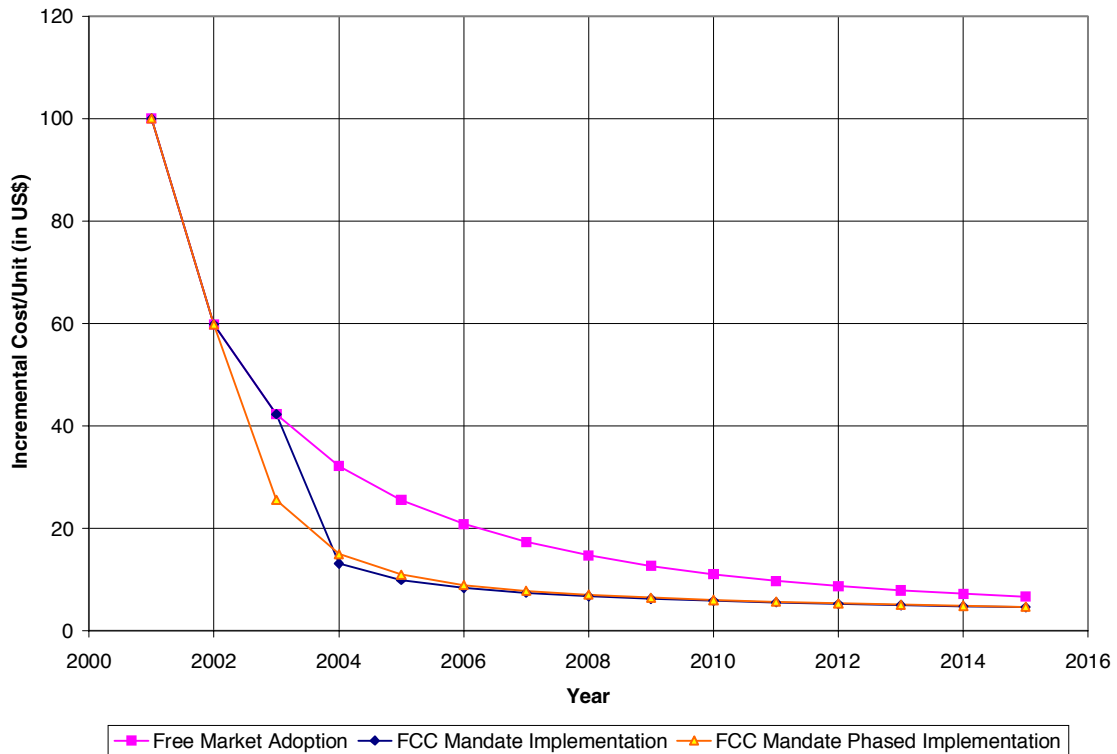

### 1.4.3 Sensitivity Analysis

To explore the sensitivity of the analysis results on key assumptions, a sensitivity analysis has been conducted, whereby the sensitivity of the results were tested relative to variations in annual TV sales, TV sales growth and incremental material cost. Note that this sensitivity analysis was applied only to the baseline scenario, as the sensitivity under this scenario will be indicative of the sensitivity under the other two scenarios.

- Variation in annual TV sales - The analysis conducted previously is based upon current annual TV sales of 25 million units per year [CEA, 2001b]. This figure however does not include the current 5 million TV/VCR combination sales [CEA, 2001b]. By increasing the current annual TV sales to 30 million units to include this category, total annual TV sales will effectively increase by 20% and the cumulative DTV sales would increase by 20% for each year under the three studied scenarios. For example, in year 2001 DTV sales will increase from the previously projected 0.21 million sets to 0.25 million, and the cumulative DTV sales in 2006 would be 11.16 million vs. 9.6 million sets previously projected for that year.

Assuming the same number of US TV households, the DTV market penetration rate will be increased accordingly. As of year 2006 under the higher projected TV Sales case, the DTV market penetration would increase from 8.5% to 10.2% in 2000 and the FCC's 85% target market penetration will be reached in 2013, one year earlier than in the previous case.

The incremental cost to incorporate a DTV receiver in new television sets, both manufacturing cost and retail price, will be the same under both annual TV Sales cases, since the cumulative sales doubling rate in the learning curve would be the same.

- Variance in annual TV sales growth – the sales forecast has been estimated under three different TV sales growth rates: low (0.75%), medium (1.5%) and high (3%). The cumulative DTV sales forecast would range from 9 million to 10 million in 2006 under the baseline scenario. The estimated DTV penetration rates range from 8% to 9% accordingly. The 85% target rate would not be realized until 2013 even under the high growth assumption.
- Variance in Incremental Cost – the cost projections have been made under a range of incremental cost assumptions: low (\$80), medium (\$100) and high (\$150). The DTV incremental cost as of 2006 would be in the range of \$16.7 to \$31.3 per TV set. The incremental retail price would be in \$30 to \$56 range by applying the same manufacturers and retail markups.

Based on the sensitivity analysis above, we conclude that the results of this report are not overly sensitive to the key assumptions.

#### ***1.4.4 Results of Cost/Price Analysis***

The cost and price impact has been examined on both integrated TV receivers and set-top box “transverters” in our analysis.

##### ***1.4.4.1 SDTV Receivers***

The following reference model for an ATSC receiver is assumed in SDTV receiver analysis:

- The TV set will be dual-mode, having the capability of receiving both analog NTSC as well as digital ATSC; and
- The TV will have the ability to transcode any valid ATSC format (i.e. from standard definition through high definition of any interlaced format) to a format that can be displayed on low level (i.e. standard definition 350 x 240) and main profile.
- Digital TVs (DTVs) are defined as TV sets capable of receiving any format of ATSC and transverting and displaying the received digital signals as Standard Definition, 480I, or SDTV only. The study excludes High Definition TVs (HDTV, 1080I or 720P) or Enhanced Definition TVs (EDTV, 480P). The results, therefore, do not include the cost of HDTV or EDTV receivers or display technology.
- Based on current consumer preference experience we assume that consumers will want so called "cable ready" DTVs, which, similar to today's analog NTSC “cable ready” TVs, will demodulate both 8-VSB broadcast signals as well as QAM cable signals. Therefore we

assume that the minimal implementation of a SDTV leader model set will be "cable ready" and capable of demodulating both 8-VSB and QAM physical layers.

This analysis focused on four study cases consisting of two market segments – “market leader (low-end)” televisions and “high-end” televisions, under two scenarios – “FCC mandate” and “free market” adoption (See Figure 3-1).

The results of market penetration and cost/price analysis for leader models over time for each of these cases are summarized in the above Figure 1-1 and Figure 1-3. As can be seen, the government mandate scenario will bring down the costs to customers more rapidly, which is due to increased unit sales and greater manufacturing efficiencies. This applies to both leader models and high-end sets. High-end models typically require about half of the incremental cost to add a DTV receiver as compared to a leader (low-end) TV set, since high-end sets already include some internal digital signal processing and memory components to support such features as picture-in-picture, line doubling resolution enhancement, etc. On the other hand, high-end sets normally have a higher manufacturer price markup (2.5 times the direct material cost compared to 1.5 times direct material cost for the market leader models) and a higher retail profit margin (35% compared to 20%, respectively). This translates to an incremental retail price increase to add a DTV receiver to a high-end set, that is approximately 94% of the retail price increase to add a DTV receiver to a market a leader model.

For example, the incremental direct material cost and corresponding retail price increase to incorporate a DTV receiver in a low-end set in 2001 is \$100 and \$180 respectively, and will decline to \$21 and \$38 respectively by 2006 under the free market rollout scenario. The comparable incremental cost and price for a high-end model is approximately \$50 and \$169 respectively in 2001, and is expected to fall to \$11 and \$35 by 2006.

#### ***1.4.4.2 Set-top Box Transverter***

Incremental cost analysis of the set-top box (STB) transverter has also been included in the report, since a consumer might consider the purchase of a transverter instead of an integrated DTV in the following two cases:

- To extend the useful life of an otherwise good analog NTSC television; and,
- When purchasing a new television, and a package consisting of a new analog television plus a transverter is more cost effective or better suits the consumers needs than any integrated DTV. (This would probably only be the case if the consumer were forced to consider a higher-end model to get a DTV receiver as their first-choice model, the one that best fits their cost/feature needs, is not available with an integrated DTV receiver).

It is assumed that the typical transverter will be capable of receiving all 18 modes of DTV and will convert whatever mode received to SDTV 480I. The typical transverter may also be capable of receiving and converting “basic” (i.e. non-scrambled) digital cable channels thus it will be “cable-ready”. This typical configuration will serve as our “reference” design in this analysis.

The SDTV set-top transverter total cost and retail price decline is shown in . Analog NTSC addressable cable set-top boxes currently cost approximately \$100 per set and we anticipate that they will remain at this price point throughout the study period. Given the technological content of the analog set-top box, it is reasonable to assume that inclusion of a DTV receiver will initially cost \$100 and that this incremental cost will fall relative to the same manufacturing learning curve associated with DTV sets. That is, given the technological similarities between SDTV set-top transverter, digital satellite set-top boxes, and DTV receivers, the set-top box transverter is expected to benefit from the same manufacturing volumes and learning curve, associated with these other products. Therefore, the cost of a set-top box transverter is expected to fall in relation to that of the integrated DTV receiver.

For example, similar to DTV receiver free market adoption baseline scenario, a set-top box transverter with total manufacturing cost of \$200 in 2001 would cost only \$121 by 2006, translating to a retail price of \$218 by applying the same markup factors as those of a leader model TV set. With the FCC mandates, however, the manufacturing cost and retail price by 2006 could be as low as \$108.4 and \$195 respectively.

**Figure 1-4 SDTV Set-top Box Transverter Cost/Price Analysis**

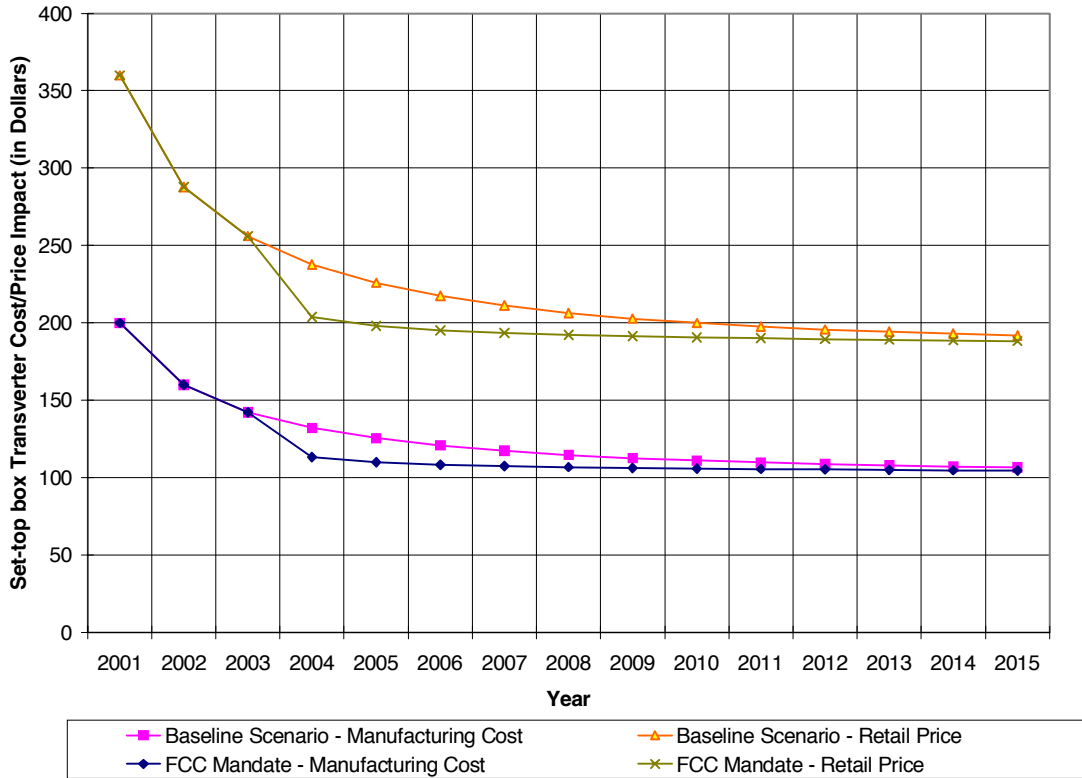

### 1.4.5 Key Uncertainties

Since the analysis in this report is based upon certain estimates and assumptions - e.g. projections of future sales and predictions of cost behavior, there is uncertainty regarding the precise accuracy of the analysis outputs. Factors capable of altering the findings include the following:

- ***Free market vs. FCC Mandated DTV adoption***

The single factor with the greatest potential impact on DTV adoption that we now face is that of FCC policy yet to be defined relative to DTV. As can be seen from this analysis, the results based on the free market adoption scenario differ significantly from the results gained under the FCC mandated scenarios. That is, cumulative DTV sales, market penetration and the incremental cost to incorporate DTV receivers in newly manufactured sets, are all very sensitive to the course chosen by the FCC. This is the most important factor having the greatest potential impact on these factors.

- ***Price Elasticity and Market Adoption***

The purchasers of low-end TV sets are expected to be more price sensitive than buyers of more expensive, higher-end sets. Therefore, the sales projections of integrated DTVs in initial years may be substantially lower due to price elasticity effects, which have not been considered in this analysis.

That is, the initial \$180 retail price increase for the inclusion of a DTV receiver could substantially impact purchasing decisions regarding low-end sets. ADL learned from interviews with a manager of a leading consumer electronics store that “consumers of ‘leader’ sets are not likely to pay more than \$60 premium for inclusion of a digital receiver”.

The manufacturing cost learning curve suggests that the incremental retail price for inclusion of a digital receiver will not fall to \$60 until 2004 under the free market adoption case, and under the government mandate scenarios it will not reach \$60 until 2003.

Prior to this time, sales of low-end “leader” models can only be explained by the behavior of “early adopters” who will pay a significant premium to have the latest product advancements. There is a risk that sales in these early years will not reach the projected level. Changes in cumulative sales would impact the manufacturing learning curve, thereby pushing the estimated cost reductions and sales projections further into the future.

- ***Forward Pricing***

Should the manufacturers adopt a Forward Pricing strategy, the retail prices may be dramatically lower in the initial years of introduction. This approach could significantly fuel a more rapid acceptance and adoption of DTV receivers than indicated by our projections, resulting in faster cost reductions.

## 2 Introduction

### 2.1 Report Organization

Details regarding methodology, assumptions and the analysis of information collected are discussed in greater detail in the remainder of this report. The overall organization of this discussion is as follows:

- **Introduction:** General background on the project and overview of the methods applied;
- **Scope and Approach:** Synopsis of the scope of the project and the overall approach to realize the objectives;
- **Key Assumptions and Data Sources:** Brief summary of the information collected for the study and introduction of a number of key assumptions applied in the analysis;
- **Cost Analysis:** This chapter describes the application of Bass Adoption Theory to the sales projections and the application of a “Learning Curve” approximation to the current cost estimates to develop estimates for market adoption and the incremental cost to incorporate DTV receivers in televisions over time and under the studied scenarios;
- **Conclusions:** Summary of the results obtained and principal conclusions reached in the analysis.

### 2.2 Background

The Advanced Television Systems Committee (ATSC) standard for U.S. broadcast digital TV (DTV) is a significant technological advance which, upon widespread DTV adoption, is expected to benefit all stakeholders. Specifically,

- Consumer electronics manufacturers, distributors and retailers would benefit from the creation of a market for a new, higher valued category of DTV receivers and video equipment. This would perhaps encourage the early retirement of the installed base of analog NTSC TV receivers (NTSC TV);
- Broadcasters would benefit by having a wider variety of transmission choices which allow for a mix of higher quality, higher resolution programs (HDTV) or, alternatively, a larger number of standard definition (SDTV) programs with the attendant additional revenue generating potential;
- Wireless systems and others with interest in acquiring spectrum would benefit from the spectrum made available from the more spectrally-efficient ATSC transmission standard; and

- The government would, by serving the mandate, be acting in the public interest providing new and valued services to consumers. The government would also collect fees for the use of the newly freed spectrum.

While there are clear benefits to the major stakeholders of achieving long-term widespread adoption of DTV, each of the stakeholders has legitimate short-term concerns as to which is the best pathway between today's largely Analog Television (ATV) world and tomorrow's Digital Television (DTV) future.

The key issue is, how can we overcome the classic "*chicken and egg*" dilemma:

- Consumers find the costs of current ATSC compatible receivers to be too expensive, given the limited ATSC program transmissions today;
- Given the limited number of ATSC compatible receivers currently in use, there is little incentive for broadcasters to incur additional operating costs and make the substantial capital investments needed to support simulcast of both NTSC and compelling ATSC programming, such as HDTV [CEA, 2000b]; and
- Manufacturers of consumer TVs and the companies developing and manufacturing integrated circuits (IC) for these TVs have limited incentives to invest in the substantial research and development (R&D) needed to drive down the costs of DTV and thereby increase the installed base of ATSC compatible receivers.

A possible mechanism to overcome this dilemma is based on the historical government action deployed by Congress to accelerate the penetration of TVs capable of receiving UHF transmissions. In this case, Congress directed the Federal Communications Commission (FCC) to develop regulations mandating the inclusion of UHF tuners in all television sets sold. This was known as the All Channel Receiver Act. While history demonstrates the success of government action in accelerating the deployment of compatible UHF TVs, there are legitimate questions being raised about undertaking a similar approach to accelerate the adoption of ATSC compatible TVs. In this instance, the main issue is cost. To incorporate an UHF tuner, the cost was sufficiently low enough to have a minimal effect on annual TV sales. In the case of adding an ATSC receiver to TVs, there is general agreement that the incremental cost would be a larger percentage of the base cost of a TV than that of an UHF tuner. This concern is of particular significance with respect to the low-end (so-called *leader model*) TVs that currently sell for retail prices below \$250. Furthermore, there is not a consensus regarding the current or future cost of adding a DTV receiver to a conventional TV.

The FCC has opened the possibility of initiating regulatory action to accelerate the adoption and deployment of DTV receivers. This could represent a "*win-win*" situation for all stakeholders by achieving the rapid deployment of both DTV receivers in concert with the rapid growth of DTV broadcast programs.

To further clarify the consequences of such action, the Association for Maximum Service Television, Inc. (MSTV) and The National Association of Broadcasters (NAB) have



commissioned Arthur D. Little, Inc (ADL) to conduct this study and develop a fact base and perspective on costs and other key issues that a decision maker would need to consider in developing DTV policy.

This report attempts to address a number issues, but the focus is on one central topic comprising two key questions:

- What is the estimated incremental material cost impact on the bill of material for a typical TV receiver to incorporate an ATSC receiver; and
- What are the retail price consequences of these extra costs?

The following report addresses these central questions.

### **2.3 Related FCC Rulemaking Activities**

In 1997, the FCC's *Fifth Report and Order* [FCC, 1997] adopted rules to implement the Telecommunications Act of 1996. This action provided that initial eligibility for advanced television licenses issued by the FCC should be limited to existing broadcasters, and conditioned on the eventual return of either the current 6MHz channel or the new digital channel. The FCC issued initial licenses for DTV, established service rules, including a requirement that broadcasters continue to provide free, over-the-air television service, and set the target date of 2006 as the completion of the transition.

After the adoption of the *Fifth Report and Order*, Congress made the 2006 reversion date statutory by enacting the Balanced Budget Act of 1997. This act provides that “[a] broadcast license that authorizes analog television service may not be renewed to authorize such service for a period that extends beyond December 31, 2006” unless the FCC grants an extension based on specific criteria enumerated in the statute [47 USC, 2000a]. In the meantime, Congress mandated that 85% of households in a market must be able to receive digital broadcast stations’ signal before analog spectrum is returned [47 USC, 2000a].

The FCC is permitted to extend the December 31, 2006 deadline on a market-by-market basis if less than 85% of the households in its market have at least one of the following [FCC, 2001c]:

- (1) digital TV receivers;
- (2) analog television receiver equipped with a digital/analog transverter; and,
- (3) access to a multi-channel video provider (Cable TV operator) that carries local digital broadcast stations.

In order to reach the goal of having digital TV in 85% of households, the FCC has requested public comment on the following issues:

- Whether the demodulation capability requirement should extend to full HDTV signals or only to SDTV signals;

- Whether there should be a phase-in approach that would initially apply a mandate only to larger screen receivers (e.g. 32 inches or larger) and then over time apply to an increasing percentage of smaller screen TV sets;
- Whether there are other plans that would result in new TV receivers being equipped with DTV capability, increasing the penetration of digital reception into U.S. households; and
- How to construct any DTV demodulation requirement within the constraints of its statutory authority, including the All Channel Receiver Act (ACRA).

## **2.4 Overview of Digital Television Technology**

DTV provides a number of consumer or viewer benefits over analog transmission. The benefits include reception of a greater variety and more channels/programs, higher quality image and sound, support for wide-format and/or high definition (HDTV), simultaneous delivery of electronic program guides and other digitally encoded information, and the promise of future information, interactive or transaction services. There are also potential benefits to the terrestrial broadcaster, cable operator, Direct Broadcast Satellite (DBS) or other television transmission operator in that the consumer benefits mentioned translate into enhanced revenue opportunities.

Digital television signals can be transported over Direct Broadcast Satellite (DBS), cable, wireless cable (Multichannel Multipoint Distribution Service (MMDS), Local Multipoint Distribution Service (LMDS) [MMDS or LMDS]), terrestrial broadcast transmitters and, potentially in the future, fiber to the home, DSL, or any other broadband transmission access technology. It should be noted that many viewing households have access to more than one medium. For example, DBS households often also receive cable or terrestrial broadcast television to receive local content. (DBS now offers ‘Local into local’ to enable subscribers to receive their local channels, but this is a relatively recent offering so many subscribers have previously made other arrangements to receive local channels.)

In the US, there are currently three different modulation schemes used to transport DTV over these media:

- 8-VSB for terrestrial over-the-air broadcast;
- QAM for cable; and
- QPSK for satellite transmission.

Each of these requires a different approach to demodulate the signal, but there are sufficient similarities to allow receivers and receiver chip-sets to support multiple or even all modes. (Note: In support of this statement, we offer that current and future expected DTV implementations are based on digital signal processing architectures for which the signal processing for each modulation is of comparable computational power. Since the signal processing function is determined mainly by firmware, i.e. software stored in a memory chip, with no incremental hardware costs, there is minimal additional signal processing costs. We understand that there are hardware differences in that cable tuners needed to operate over a wider tuning range and provide lower distortion products versus terrestrial broadcast needs to control

longer delay multipath, but consider these hardware cost differences to balance out and therefore as immaterial.)

Current analog TVs sold in the US market support direct reception of both terrestrial broadcast signals and cable channels. These “cable-ready” sets enable the consumer to receive ‘basic’ cable (as opposed to scrambled “premium” cable) without an external set-top box, and to control their video system with a single remote control. However, to receive premium programming, an external set-top device or set-back decoder (sometimes called a Point of Deployment device, or POD) is needed to provide a conditional access means to decode/descramble the premium programs.

Given today's availability of cable ready analog TVs, and that Congress has mandated future TVs to be compatible with cable [1992 Cable Act, 1992; FCC, 1993c], it is likely that the DTV counterpart to analog cable-ready TVs may develop. In such a case, the popular form of DTV television receivers will be capable of receiving and demodulating non-scrambled digital or analog terrestrial signals and non-scrambled digital or analog cable channels. And with a service provider supplied external conditional access device, such cable ready TVs will also be compatible with premium (e.g. scrambled) terrestrial broadcast and cable channels in either analog or digital formats.

Figure 2-1 Alternative DTV Transmission and Reception Approaches

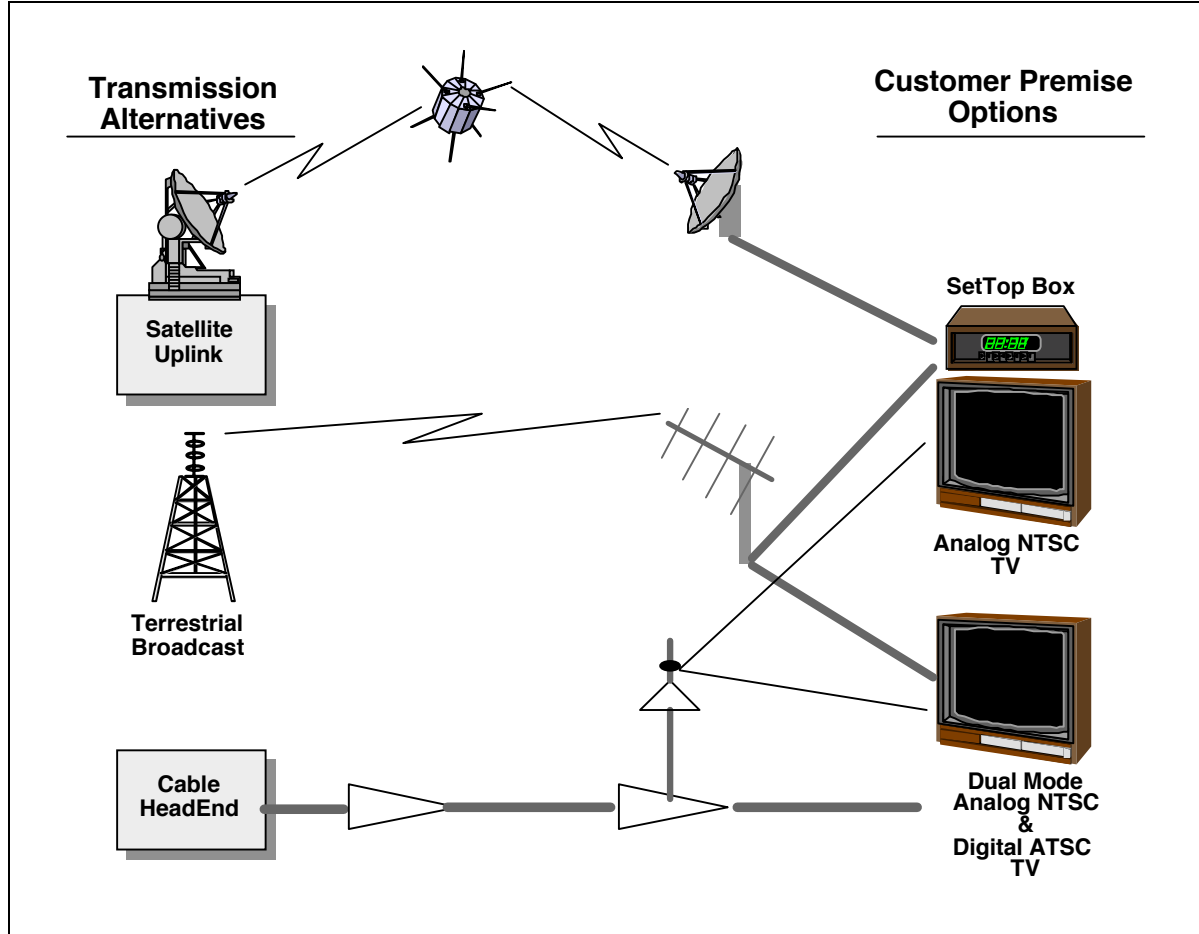

Figure 2-1 illustrates the options for transmission and reception of DTV. In particular, three alternative means of transmission are shown:

- DBS
- Terrestrial; and
- Cable.

Also illustrated are two alternative means of reception: with and without a set-top box. This study considers only the costs associated with terrestrial broadcasting of DTV with a primary focus upon a consumer TV without a set-top box. A secondary focus of the analysis is the cost of a set-top transverter capable of converting ATSC DTV to analog NTSC TV. While this study is focused on DTV, it is recognized that integrated circuits and technology developed for DBS and digital cable DTV significantly overlap terrestrial DTV technology. It is therefore expected that the development and manufacturing of digital TV receivers for DBS and cable will also drive down the costs for terrestrial DTV receivers.

### **2.4.1 MPEG-2 Standard**

Common to ATSC terrestrial DTV, DBS, and digital cable is the MPEG-2 compression standard. Essentially, this standard breaks the analog picture frame into a matrix of vertical and horizontal picture elements or “pixels”. The brightness and color of each analog pixel is “sampled” and the sample is encoded as a digital value corresponding to the brightness level and color.

Complex mathematical approaches are used to compress the digital signals and reduce the bandwidth required for transmission. For example, expressing adjacent pixels and large areas of the frame that have the same brightness/color levels in a shared representation reduces spatial redundancy. Similarly, temporal redundancy that occurs when sequential frames have common images is encoded in a manner to save bandwidth. Additionally, samples are predicted using natural order schemes based on the recognition that drastic differences between adjacent pixels seldom occur in normal images. There are different forms of MPEG-2, but the form used in ATSC is denoted as the “*Main Profile*.” It includes independent, predictive, and bi-directional frames. The cost forecasts in this study assume full compatibility with ATSC and, therefore, MPEG-2 Main Profile.

The compressed signal is “encoded” to provide error-correction redundancy and time-interleaved to spread the transmitted information in time. The latter protects against losing entire time segments when the transmission channel creates “burst errors.”

As previously discussed, a single allocated spectral channel may carry multiple television channels, currently between one and ten. It follows that individual MPEG encoded programs are “multiplexed”, or interleaved according to the respective bandwidth of each individual channel.

### **2.4.2 Overview of ATSC Formats**

ATSC defines 18 distinct formats for DTV. Each format corresponds to a different number of horizontal and vertical pixels and whether the horizontal scan lines of the picture are progressive or interlaced. Consequently, each format requires a different bandwidth requirement for transmission.

Note that all digital televisions are expected to receive all 18 formats but not all will be capable of utilizing or displaying the full enhancements associated with the higher formats. In the latter case, the TV receiver will reduce the received signal to that of a lower format for display.

For the purposes of this study, the incremental costs of displaying so called *Standard Definition TV* (SDTV) of 704 x 480 interlaced picture elements (Pixels) in a 4:3 aspect ratio is considered. This SDTV format is commonly denoted *480I*. Figure 2-2 [Whitaker/NAB, DTV the Revolution in Digital Video] shows the 18 formats defined by ATSC.

Figure 2-2 ATSC Digital Television Formats<sup>1</sup>

| <i>Vertical Lines</i> | <i>Picture Elements (Pixels)</i> | <i>Aspect Ratio</i> | <i>Picture Rates (I=interlaced &amp; P=progressive)</i> |
|-----------------------|----------------------------------|---------------------|---|
| 1080                  | 1920                             | 16:9                | 60I, 30P, 24P   |
| 720                   | 1280                             | 16:9                | 60I, 30P, 24P   |
| 480                   | 704                              | 16:9 or 4:3         | 60P, 60I, 30P, 24P                                      |
| 480                   | 640                              | 4:3                 | 60P, 60I, 30P, 24P                                      |

---

<sup>1</sup> For compatibility with NTSC, frame rates at (1000/1001) x listed frame rate are also supported. Thus, there are actually 36 formats, although it is common to refer to 18.

## 3 Scope and Approach

### 3.1 Scope

Arthur D. Little, Inc. (ADL) was commissioned by the Association for Maximum Service Television, Inc. (MSTV) and the National Association of Broadcasters (NAB) to develop cost estimates for the incremental direct material required to enable consumer electronics television (TV) sets to receive SDTV ATSC DTV transmissions. We have also estimated the effect of these cost increases on the retail prices for DTV sets.

The main focus of the project is television receivers. This report also includes estimates of cost and retail price of set-top box “transverters” as a secondary topic to investigate the price and cost decline of DTV sets over time.

#### *3.1.1 Reference-model of Television Receiver*

For the purpose of establishing a consistent baseline, the following reference model for an ATSC receiver is assumed in all cases:

- The TV set will be dual-mode, having the capability of receiving both analog NTSC as well as digital ATSC; and
- The TV will have the ability to transcode any valid ATSC format (i.e. from standard definition through high definition) to a format that can be displayed on low level (i.e. standard definition 350 x 240) and main profile of the MPEG-2 standard.
- For the purpose of this report, we assume that consumers will want so called "cable ready" TVs, and that parallel to today's situations will want these TVs to demodulate both 8-VSB broadcast signals as well as QAM cable signals. Therefore we assume that the minimal implementation of a SDTV leader model set will be "cable ready" and capable of demodulating both 8-VSB and QAM physical layers.

Consistent with these assumptions, Digital TVs (DTVs) are defined as TV receivers capable of receiving any format of ATSC and transverting and displaying the received digital signals as Standard Definition, 480I, or SDTV only. The study excludes High Definition TVs (HDTV, 1080I or 720P) or Enhanced Definition TVs (EDTV, 480P). The results, therefore, do not include the cost for inclusion of a HDTV or EDTV receiver or display.

It is noted that the incremental cost is estimated by the direct material (DM) cost. The DM cost is used, in turn, to estimate factory cost by applying typical “mark up” factors to account for labor, indirect costs, and operating profits. The factory cost estimates are further adjusted by industry typical “mark up” factors to serve as a basis for computing the likely retail price to the consumer. While this approach does not explicitly compute manufacturers’ research and development (R&D) investment or other indirect costs, the effect of such costs on the final retail

price is accounted for by applying a series of “mark-up” factors that typically account for such investments and costs.

All case studied in this report share the above assumptions.

The following alternatives have been examined:

- Regulatory Alternatives:
  - Case 1) Government mandates to include DTV capability in a fraction of new sets according to a specific timetable.
  - Case 2) Adoption by consumers is determined by normal market forces without government intervention.
- TV Receiver Baseline Alternatives:
  - Case A) A low-end leader model NTSC color TV is baseline from which to measure the incremental costs.
  - Case B) A high-end model NTSC color TV that already incorporates digital signal processing components (e.g. picture-in-picture and comb filtering). Since such sets intrinsically include substantial digital signal processing and memory, they may be assumed to accommodate DTV with a lower incremental cost than the sets in Case A.

These alternatives are presented in Figure 3-1.

**Figure 3-1 Summary of Study Cases**

|   | <b>Case A: Leader</b> | <b>Case B: HighEnd</b> |
|---|-----------------------|------------------------|
| <b>Case 1: Government Mandates 100% DTV</b>       | <b>1A</b>             | <b>1B</b>              |
| <b>Case 2: Marketplace Decides Volume Rollout</b> | <b>2A</b>             | <b>2B</b>              |

### ***3.1.2 Set-Top Transverter***

An analysis is included for a minimal implementation of a set-top transverter suitable for use with existing TV receivers to receive digital signals.



### 3.1.3 TV Receivers vs. Set-top boxes

In particular, we are attempting to determine the incremental costs for the components to enable DTV reception and display in addition to supporting existing TV.

We provide in Figure 3-2 below a simplified diagram of a leader model NTSC analog TV, where it is assumed that there is no built-in capability for enhanced digital functions such as progressive scan display or picture-in-picture.

**Figure 3-2 Simplified Block Diagram of Leader Model NTSC Analog TV Receiver**

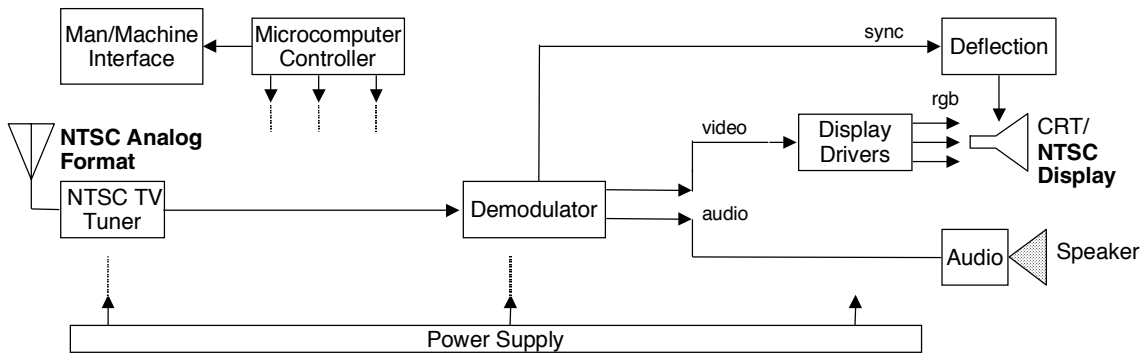

In order to enable SDTV reception, the incremental components will be included as shown in Figure 3-3 below.

**Figure 3-3 Simplified Block Diagram of SDTV Receiver**

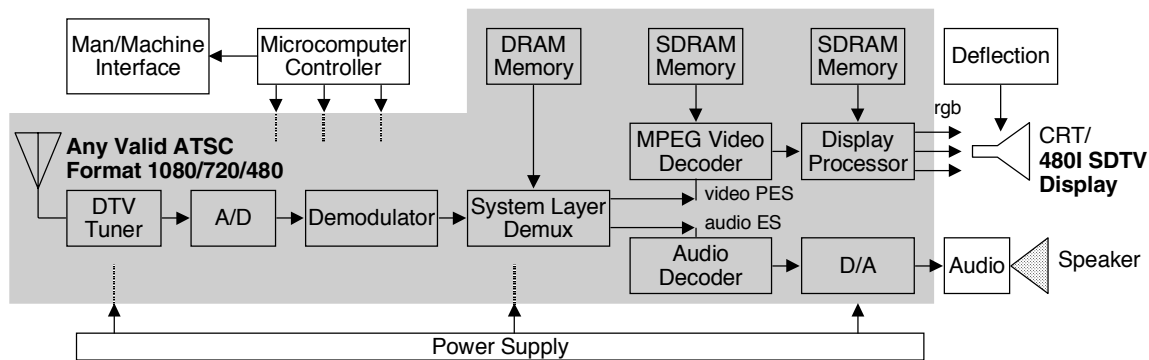

In Figure 3-3, one can see that substantial additional functions which in today's DTV receivers are often distributed among four to five custom integrated circuits. However, next generation chip sets are already being introduced to reduce IC package count, and thereby costs, by two to three times. What is notable about the shaded area is that the semiconductor devices are based on digital logic which has the well-known property of continuous cost reduction directly tied to manufacturing volume and learning curve experience. It is also the case that supporting standard

integrated circuits, most notably memory, has costs tied to markets for a broad range of consumer and non-consumer products in computing and telecommunications products.

We have also included the set-top transverters in our analysis. In Figure 3-4 below, we show a simplified block diagram of such a set-top box transverter.

**Figure 3-4 DTV Transverter Set-top Box for DTV Reception on Conventional Analog NTSC TV Receiver**

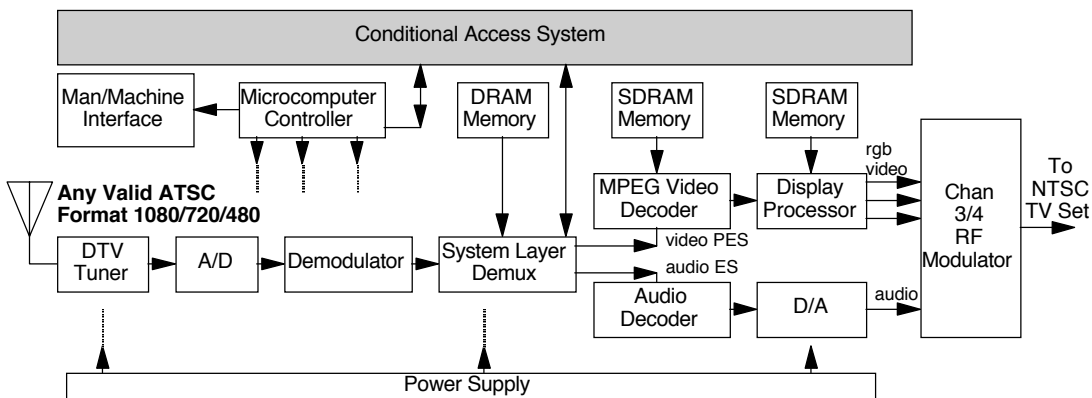

Figure 3-4 above shows that a set-top box transverter includes many of the same DTV components as a SDTV receiver. Since we are only considering the ability to receive “free” TV (i.e. non-pay non-premium TV), we have not included cost of the Conditional Access System (CAS). The cost of a digital receiver in a set-top transverter would then be essentially the same as the incremental costs to enable an analog NTSC TV receiver to receive ATSC transmissions and display SDTV at 480I. However, since a set-top transverter includes housing, power supply, and other components normally included in an analog TV. These additional costs need to be taken into account.

## 3.2 Approach

### 3.2.1 Methodology Overview

This project applies standard engineering and business analysis methods to publicly available information and the non-proprietary existing knowledge base of ADL staff, NAB staff, and MSTV staff. Additionally, interviews have been conducted with selected industry participants having knowledge or opinions that are relevant to this analysis, to supplement the available information and validate key assumptions.

The approach for both TV receivers and set-top transverters is to develop both estimates in an integrated set of tasks. The approach, however, differs in the exact methods employed:

- TV receivers: A bottom up approach in which the additional direct material costs are estimated; and

- Set-top transverters: A top down approach in which today's costs of DTV based DBS integrated receiver decoders (IRD), set-top boxes and digital cable set-top boxes are adjusted to estimate the costs of a terrestrial broadcast DTV transverter.

In particular, the following tasks have been undertaken:

- Conducted research on publicly available information regarding DTV sets, integrated circuit chip sets, set-top boxes, and other analogous consumer electronics products. These public data cover current technology, costs and industry predictions on evolution to high levels of semiconductor integration and cost reductions;
- Developed key assumptions based on the public information available as well as the expert knowledge of ADL staff. These assumptions include today's incremental costs to implement DTV compatible reception as well as the estimated cumulative volume of relevant DTV technology manufactured to date;
- Developed a baseline forecast for DTV shipments based on market adoption mathematical models;
- Developed predictions of manufacturing cost reduction over time using Learning Curve theory and sales projections;
- Conducted interviews with 3<sup>rd</sup> party industry stakeholders, including TV manufacturers, IC suppliers and TV retailers to review and refine the initial input assumptions and the model structure; and
- Incorporated the interview results into the ADL model and development of final estimates.

Figure 3-5 summarizes the approach and methodology that we have adopted in this analysis.

**Figure 3-5 Analysis Approach and Methodology Overview**

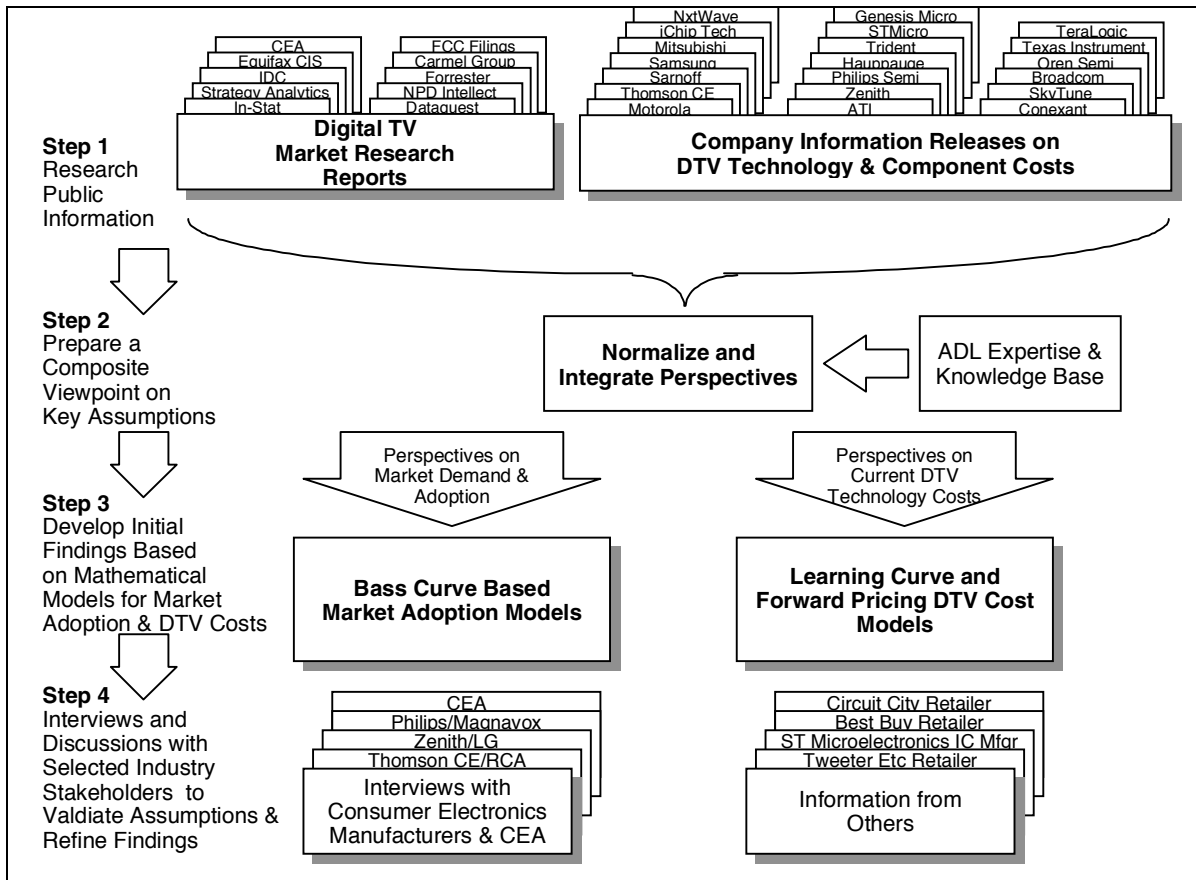

### 3.2.2 Details of Methodology

The analysis is based on the following methods:

#### 3.2.2.1 Market Adoption Models - Bass Adoption Curve

For purposes of these estimates, the Bass Adoption Curve methodology has been applied to produce a DTV sales forecast. By applying historical data from analogy products (color TV in our case), DTV market adoption curves for the next 15 years under different scenarios were developed. By applying this approach, three major estimates were developed:

- Total size of the addressable market for DTV;
- Year-by-year DTV adoption based on adoption rate for the DTV; and
- DTV’s market penetration in the future 15 years

### **3.2.2.2    *Learning Curve***

To estimate the future reduction in cost, a manufacturing learning curve has been applied. To apply this method, the forecast annual TV shipments were integrated to provide cumulative shipments of DTV receivers. Learning Curve theory implies that a specific reduction in production cost occurs each time accumulated sales double. In this report, we applied a 75% learning curve factor (or 25% of cost reduction) to calculate the average incremental cost for a digital receiver added to a typical TV over a 15 year future forecasting interval.

### **3.2.2.3    *Forward Pricing***

The impact of forward pricing upon the retail cost of a digital receiver was also examined. Forward pricing is a commonly adopted pricing strategy in the semiconductor and consumer electronics industry used to accelerate consumer adoption of new products. In forward pricing, the manufacturers set a retail price lower than the manufacturing cost in anticipation of future cost reductions to stimulate sales. [Japanese High Tech Review, 1990]

The baseline scenario assessed in this report considers cases with and without the application of forward pricing.

## **4 Key Assumptions and Data Sources**

The central focus of this analysis is to develop an assessment of the likely penetration of integrated digital televisions (DTV). To develop a basis for this assessment, it is necessary to obtain forecasts for general television sales and, in particular, for sales of digital televisions and set top boxes. These forecasts were obtained primarily through the following sources:

- Publicly available information from various sources including industry analyses;
- Non-proprietary knowledge of ADL and NAB/MSTV staff; and
- Selected interviews with industry stakeholders.

This section outlines, in summary form, the data that were obtained. The detailed supporting data are provided in Appendix A. The analysis of potential market penetration and cost impacts of digital television and set-top transverters based on these data is presented in Section 5.

### **4.1 Key Data Resources**

As described above, key data were obtained to describe historical sales and pricing of relevant products. Additionally, various estimates of the cost to implement digital capabilities were obtained. Representative sources of information are summarized in Table 4-1. Citations for sources applied are presented in the reference list in Section 7. The following sections summarize these estimates.

**Table 4-1 Representative Information Sources Applied in Analysis**

| <b><i>Information Source</i></b>                     | <b><i>Representative Sources</i></b>  |
|--|---|
| <b><i>U.S. Federal Communications Commission</i></b> | <ul style="list-style-type: none"> <li>• Report and Order and Further Notice of Proposed Rule Making, MM Docket No. 00-39, Review of the Commission’s Rules and Policies Affecting the Conversion to Digital Television</li> <li>• Notice of Proposed Rule Making, MM Docket No. 00-39, Review of the Commission’s Rules and Policies Affecting the Conversion to Digital Television, Comments of Thomson Multimedia, Inc.</li> <li>• Report and Order, 8 FCC Rcd2965 (1993), Implementation of the Cable Television Consumer Protection and Competition Act of 1992, “Broadcast Signal Carriage Issues (‘Must-Carry Order’)”</li> <li>• “Broadcast Signal Carriage Issues, Memorandum Report and Order (‘Must-Carry Reconsideration’)”</li> </ul> <p>Fifth Report and Order, 12 FCC Rcd 12841-42</p> |
| <b><i>U.S. Regulations/Law</i></b>                   | 47 U.S.C. §309 (j) (14), §§534, 535, 47 C.F.R. §73.624(d)   |
| <b><i>Consumer Electronics Publications</i></b>      | <ul style="list-style-type: none"> <li>• CEA Market Research, 1996 – 2001 US Consumer Electronics Sales and Forecast, Issued January 2001, Direct-View Color TV Receivers, Digital TV sets and Displays, VCR Decks, TV/VCR Combinations, Personal Computers</li> <li>• DigitalAmerica 2001, US Consumer Electronics Industry Today: Digital Television Gains Momentum, Consumers Are Ready for DTV</li> <li>• DTVGuide, May 2001, Digital TV Set Top Decoders</li> <li>• eBrain Market Research: CE Future Interactive Forecast Database</li> </ul>   |
| <b><i>Industry Studies</i></b>                       | <ul style="list-style-type: none"> <li>• The Carmel Group: US Personal TV Subscriber Forecast, DBS Investor, May 2001; US Analog/Digital TV Set-top Receiver Forecast, DBS Investor, June, 2001</li> <li>• Cahner In-Stat: HDTV: What is Going Wrong (Technology Information), Electronic News (1991), January 1, 2001</li> <li>• Strategy Analytics: HDTV Faces Long Haul Says Strategy Analytics, PR Newswire, 3094, December 2, 1998</li> <li>• Ovum: DTV: How to survive and make money, September, 1998</li> </ul> <p>Paul Kagan Associates: Kagan’s DBS Industry Projections 2000-2010, Cable World, April 30, 2001</p>   |
| <b><i>Press Releases</i></b>                         | <ul style="list-style-type: none"> <li>• STMicroelectronics</li> <li>• Motorola,</li> <li>• Thomson Consumer Electronics,</li> <li>• Sarnoff,</li> <li>• Samsung,</li> <li>• Mitsubishi,</li> <li>• Zenith,</li> <li>• Philips Semiconductors,</li> <li>• Conexant,</li> <li>• Broadcom,</li> <li>• Oren Semiconductor,</li> <li>• Texas Instruments,</li> <li>• iChip Technology,</li> <li>• TeraLogic,</li> <li>• NxtWave Communications</li> </ul>   |
| <b><i>Retail Dealer</i></b>                          | <ul style="list-style-type: none"> <li>• Tweeter, Etc., Circuit City, Best Buy</li> </ul>   |



### 4.1.1 Estimates of Digital TV Sales

Several sources of market estimates pertaining to DTV sales were considered in the course of this study. These sources present a range of estimates for various segments of the market and are not directly comparable due to the differences in the assumptions and segments analyzed. Nonetheless, they provide general perspective on the range of sales that are expected.

U.S. sales of TV sets to dealers have been reported by the industry [Consumer Electronics Association (CEA), 2001a]. Their projections are shown in Figure 4-1 and indicate that, in 2000, annual Digital TV sales were 0.65 million units and are projected to rise to 10.5 million units by 2006. Note that these CEA projection numbers include both integrated DTV sets and the DTV displays. Based on comments made at the CEA conference, only about 10 to 20 percent of the DTV digital receivers are integrated DTV sets which can receive over-the-air digital signals [CEA, 2001d]. By applying the 20% factor to the CEA projections, we obtain the adjusted CEA forecast on integrated DTV sales included in Figure 4-1.

**Figure 4-1 Projected Sales of Digital Television Receivers and Displays**

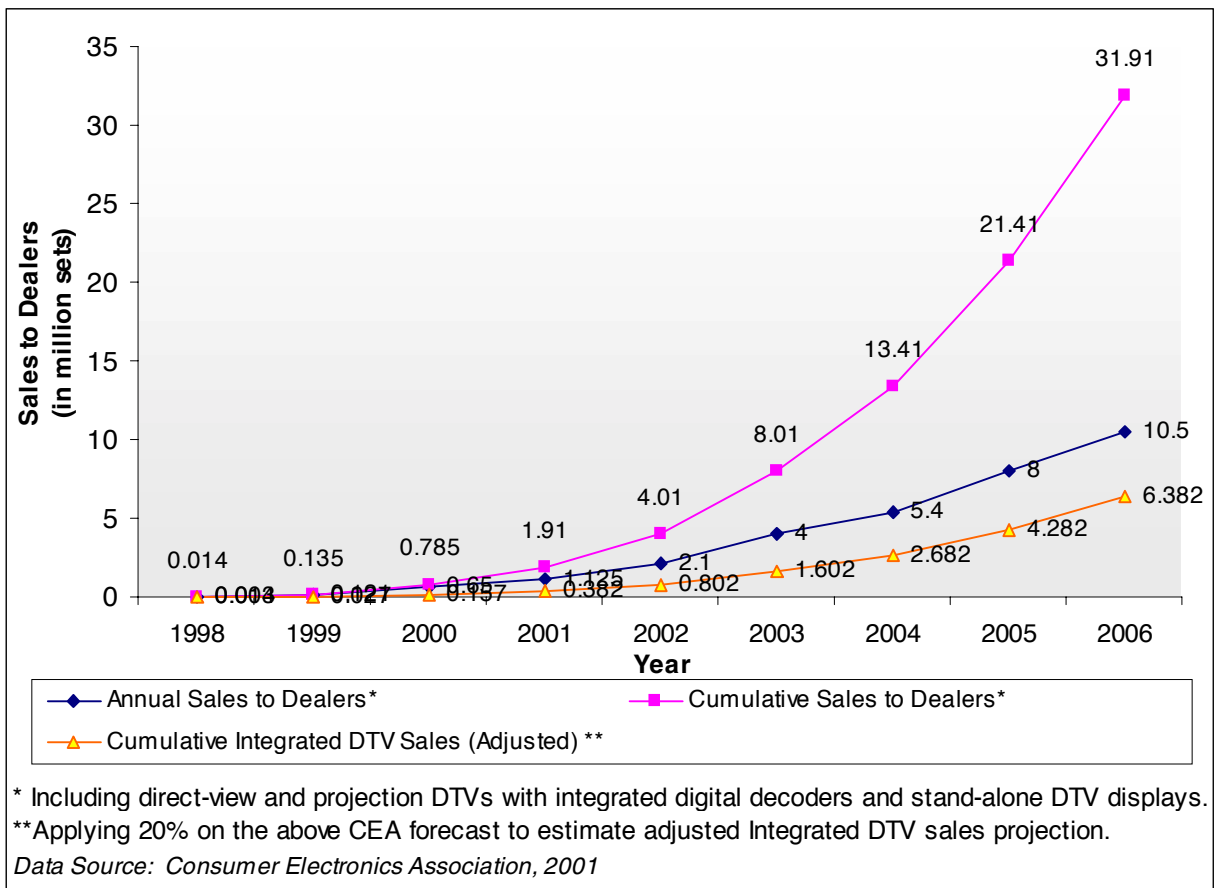

The Cahner In-Stat Group also reported annual shipments of HDTV products [Cahner In-Stat, 2001], projected to rise from 0.6 million sets in 2000 to nearly 10 million sets by 2004. The products included are not specially stated but are believed to include HDTV sets, set-top boxes and “HD ready” digital receivers such as PC-HDTV. According to the CEA [CEA, 2001a], approximately 86% of digital receivers are HDTV capable. Applying this factor to the CEA 2000 estimate of 0.65 million digital TV sets and displays sold, yields a 2000 estimate of 0.56 million digital sets sold compared to the Cahner In-Stat estimate of 0.60 HDTV products. Therefore, the two forecasts are in general agreement. In 2004, CEA projects total digital TV sales of 5.4 million versus the Cahner In-Stat estimate of 9.975 million HDTV products. Again applying the assumption that 86% of TV sets sold are HDTV capable, the CEA estimate corresponds to approximately 4.6 million HDTV sets which is inconsistent with the Cahner In-Stat estimate of 9.975 million HDTV products. It appears likely, however, that the fraction of digital TVs that are HDTV capable will rise by 2004 and that other HDTV products such as set-top boxes will become more prevalent. These effects could at least partially explain the discrepancy with the remainder likely attributable to differences in the methods used to project future sales. Thus, it appears that, to within the uncertainties regarding the collected data, the two projections are in reasonable agreement.

**Figure 4-2 U.S. HDTV Product Shipments**

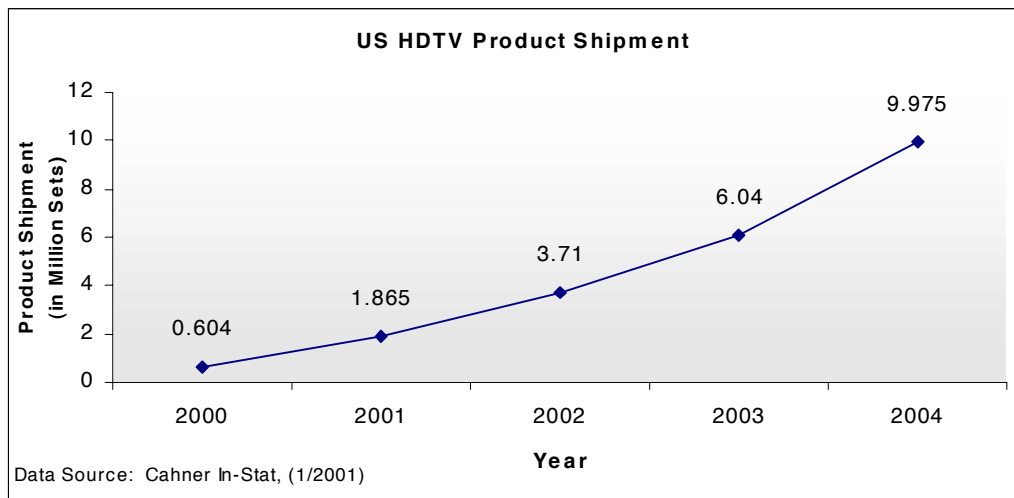

Additional data on U.S. DTV receiver sales are presented in Figure 4-3. These values are presented by Strategy Analytics, Inc. [Strategy Analytics, Inc., 1998] and show sales of 0.3 Million units in 2000, rising to 2.4 Million in 2005. By 2004, the prediction is approximately 1.7 million sets sold.

Figure 4-3 U.S. DTV Sales

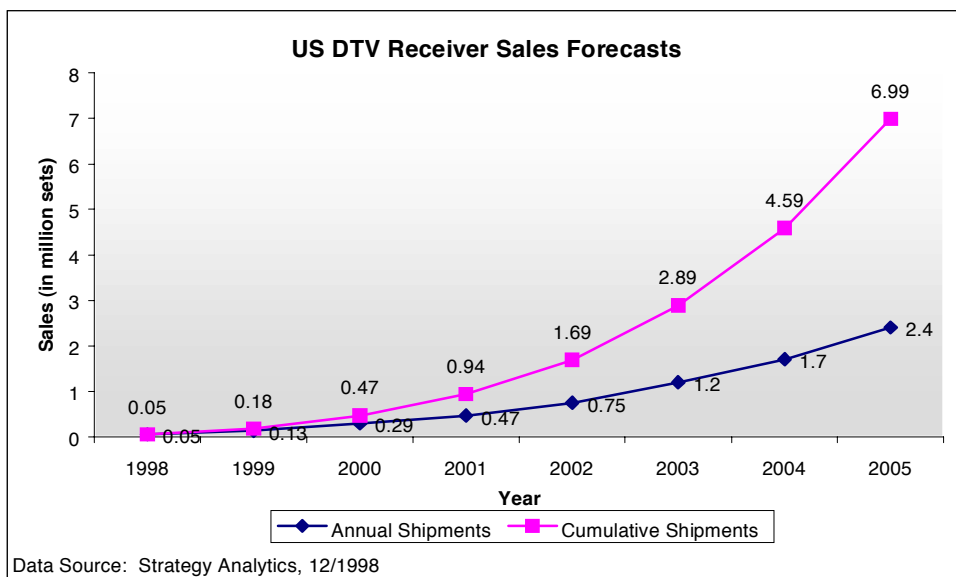

Also, Ovum projected the US Digital TV subscribers [Ovum, 1998] in Figure 4-4. As shown, the dominant near term delivery channel is via satellite, with satellite TV subscribers at 10.0 million in 2000, projected to rise to 16 million in 2004 and 17.2 million in 2005. The number of Terrestrial digital TV subscribers is 3.506 million in 2000, projected to rise to 8.991 million by 2004 and to 9.454 million by 2005.

Figure 4-4 US Digital TV Subscriber Forecast

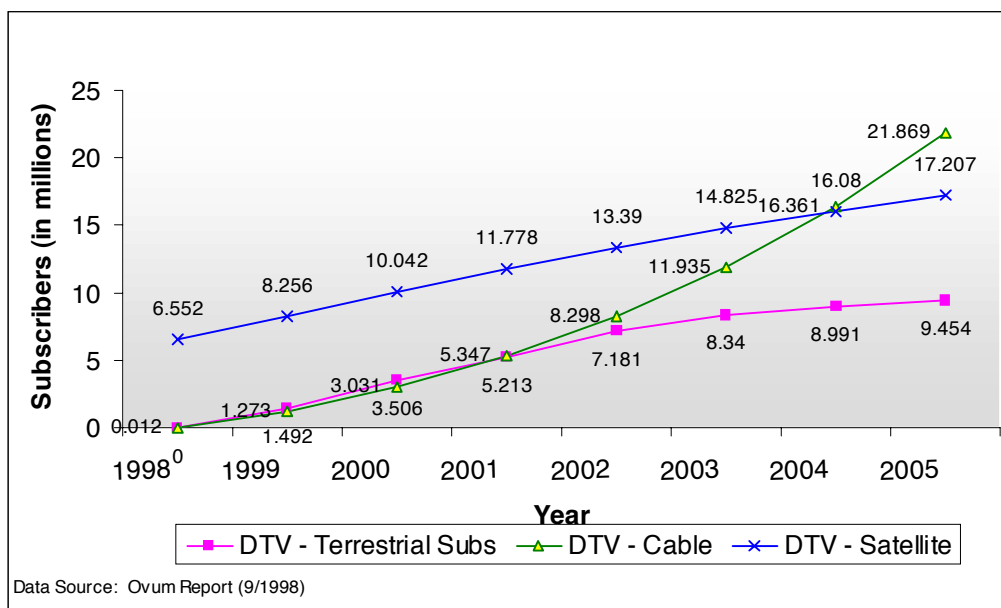

Table 4-2 summarizes the various estimates of DTV sales from the current year to 2004. Overall, the near term estimates are in reasonable agreement with two of the observations being very close, particularly if the CEA estimate is adjusted to reflect HDTV product sales only. The 2004 projections vary more widely.

**Table 4-2 Summary of DTV Sales (Million Units)**

| <b>Source</b>             | <b>Estimate</b>             | <b>2000</b> | <b>2004</b> |
|---------------------------|-----------------------------|-------------|-------------|
| <i>CEA</i>                | DTV Dealer Sales            | 0.65        | 5.4         |
| <i>CEA</i>                | Integrated DTV Sales*       | 0.13        | 1.08        |
| <i>Cahner's</i>           | HDTV Products               | 0.60        | 10.0        |
| <i>Strategy Analytics</i> | DTV Receivers               | 0.3         | 1.7         |
| <i>Ovum</i>               | Terrestrial DTV Subscribers | 3.5         | 8.99        |

\* We assume that 20% of the total projected DTV sets can receive over-the-air digital signals, or as the integrated DTV sets.

#### ***4.1.2 Retail Prices on existing DTV products and Set-top Boxes***

To provide perspective on cost estimates, data were collected regarding the current retail prices of DTV products and set-top boxes. These data are presented in Table 4-3 [CEA, 2001c].

**Table 4-3 Suggested Retail Prices of Digital TV Set-top Decoders**

| <b>Brand</b>                   | <b>Model</b>   | <b>DTV Formats Received</b>  | <b>Scan Conversion (Input &gt; Output)</b>  | <b>Date Available</b> | <b>Suggested Retail Price</b>                        |
|--------------------------------|--|--|---|-----------------------|--|
| Echostar                       | 6000**   | Core 18 ATSC<br>Table 3 Formats<br>(with optional<br>tuner module) | All Formats>480i; All<br>Formats>1080i; All<br>Formats>720p   | Now                   | \$499.95<br>(optional<br>ATSC tuner<br>module \$100) |
| Motorola/General<br>Instrument | HDD200***<br>Adapter module for<br>4DTV digital C-<br>band Decoder | C-Band; No<br>ATSC tuner<br>included                               | Selectable: All<br>Formats>480p; All<br>Formats>720p; All<br>Formats>1080i  | Now                   | \$ 1,599.99  |
| Hughes Network System          | HSYS-E8674<br>Platinum HD*   | Core 18 ATSC<br>Table 3 Formats                                    | All Formats>480i; All<br>Formats>1080i  | Now                   | \$799.95 with<br>multi-satellite<br>dish             |
| Hughes Network System          | HIRD-E86<br>Platinum HD*   | Core 18 ATSC<br>Table 3 Formats                                    | All Formats>480i; All<br>Formats>1080i  | Now                   | \$649.95<br>without dish                             |
| Integra                        | IT815ST Formerly<br>Unity Motion HDR<br>1000A                      | Core 18 ATSC<br>Table 3 Formats                                    | HD Formats>1080i; SD<br>Formats>480p  | Now                   | \$ 795.95  |
| JVC                            | TU6000RU**   | Core 18 ATSC<br>Table 3 Formats<br>(with optional<br>tuner module) | All Formats>480i; All<br>Formats>1080i; All<br>Formats>720p   | Now                   | \$499.95<br>(optional<br>ATSC tuner<br>module \$149) |
| Konka                          | HD-0001  | Core 18 ATSC<br>Table 3 Formats                                    | All Formats>1080i   | TBA                   | \$ 999.95  |
| Loewe                          | HDT-100  | Core 18 ATSC<br>Table 3 Formats                                    | Switchable: All<br>Formats>480i; All<br>Formats>480p; All<br>Formats>720p; All<br>Formats>1080i                       | Now                   | \$ 1,600.00  |
| Macro Image Technology         | MDR-100  | Core 18 ATSC<br>Table 3 Formats                                    | Switchable: All<br>Formats>480i; All<br>Formats>480p; All<br>Formats>720p; All<br>Formats>1080i                       | TBA                   | TBA  |
| Macro Image Technology         | MDR-500  | Core 18 ATSC<br>Table 3 Formats                                    | Switchable: All<br>Formats>480i; All<br>Formats>480p; All<br>Formats>720p; All<br>Formats>1080i; All<br>Formats>1080p | TBA                   | TBA  |
| Mitsubishi                     | SR-HD500*  | Core 18 ATSC<br>Table 3 Formats                                    | All Formats>480i; All<br>Formats>1080i  | Now                   | \$1049.95<br>(includes dish)                         |
| Mitsubishi                     | SR-HD400*  | Core 18 ATSC<br>Table 3 Formats                                    | All Formats>480i; All<br>Formats>1080i;   | Now                   | \$825.95<br>(omits<br>DirecTV dish)                  |

(Continued)

| Brand                      | Model                            | DTV Formats Received            | Scan Conversion (Input > Output)   | Date Available | Suggested Retail Price       |
|----------------------------|----------------------------------|---------------------------------|--|----------------|------------------------------|
| Panasonic                  | TU-HDS20*                        | Core 18 ATSC<br>Table 3 Formats | All formats> Any Output Selected   | Now            | \$899.95 (dish not included) |
| Philips                    | DSHD800R*                        | Core 18 ATSC<br>Table 3 Formats | All Formats>480i; All<br>Formats>1080i;  | Now            | \$ 999.00                    |
| Pioneer                    | SH-D505                          | Core 18 ATSC<br>Table 3 Formats | Switchable; All<br>Formats>480p; All<br>Formats>720p; All<br>Formats>1080i                             | Now            | \$ 2,499.99                  |
| Pioneer                    | SH-D09                           | Core 18 ATSC<br>Table 3 Formats | Switchable; All<br>Formats>480i; All<br>Formats>1080i; All<br>Formats>480p                             | Now            | \$ 2,499.99                  |
| Princeton Graphics Systems | HDT-2000                         | Core 18 ATSC<br>Table 3 Formats | All Formats>1080i;   | Now            | \$ 899.00                    |
| ProScan                    | PSHD105*                         | Core 18 ATSC<br>Table 3 Formats | Switchable; All<br>Formats>480i; All<br>Formats>540p;<br>720p>1080i,<br>1080i>1080i                    | Now            | \$549.99<br>without dish     |
| Proton                     | TBA                              | Core 18 ATSC<br>Table 3 Formats | Switchable; All<br>Formats>480i; All<br>Formats in Native Form,<br>720p>480p;<br>1080i>480p, 480i>480p | TBA            | TBA                          |
| RCA                        | DTC100*                          | Core 18 ATSC<br>Table 3 Formats | Switchable, All<br>Formats>480i; All<br>Formats>540p;<br>720p>1080i;<br>1080i>1080i                    | Now            | \$549.99<br>(without Dish)   |
| Samsung                    | SIR-T150 (with<br>3rd gen. Chip) | Core 18 ATSC<br>Table 3 Formats | Switchable, All<br>Formats>480p; All<br>Formats>720p; All<br>Formats>1080i; All<br>Formats>NTSC        | Now            | \$ 699.00                    |
| Sony                       | SAT-HD100*                       | Core 18 ATSC<br>Table 3 Formats | Switchable, All<br>Formats>480i; All<br>Formats>1080i  | Now            | \$ 799.99                    |
| Toshiba                    | DST-3000*                        | Core 18 ATSC<br>Table 3 Formats | Switchable, All<br>Formats>480i; All<br>Formats>1080i  | Now            | \$799.99 w/o<br>dish         |
| Zenith                     | DTV1080* (with<br>3rd gen. Chip) | Core 18 ATSC<br>Table 3 Formats | All Formats>1080i,<br>720p, 480p, 480i, All<br>Formats >NTSC   | Q3-01          | 799.95                       |

\* Also receives DirectTV standard and HD satellite services

\*\* Also receives Dish Network standard and HD satellite services

\*\*\* Receives HD signals from digital C-band satellites

Data Source: DTVGuide by CEA, July 2001

### 4.1.3 Cost Information

To estimate the cost impact associated with the inclusion of a DTV receiver, it is necessary to develop estimates of the incremental cost to implement digital capabilities in TV receiver designs. To develop these estimates, several data sources have been researched including:

- Public filings with the Federal Communications Commission that addresses the cost of digital TV implementation;
- Component cost estimates from manufacturer's literature; and
- Interviews with selected industry representatives.

This section summarizes the data that were obtained.

#### 4.1.3.1 FCC Filings (Responses to FCC NPRM)

On April 6, 2001, Thomson Multimedia, Inc. (Thomson) filed comments with the FCC [FCC, 2001b] indicating the incremental manufacturing cost of implementing DTV reception capability in an average TV set to be as summarized in Table 4-4:

**Table 4-4 Summary of Thomson Incremental Manufacturing Cost Estimates**

| <i>Item</i>                 | <i>Cost Estimate</i> |
|-----------------------------|----------------------|
| Mechanical parts            | \$30-\$45            |
| HD MPEG decoder             | \$40-\$55            |
| VSB IC                      | \$25-\$40            |
| Memory                      | \$35-\$50            |
| Misc. Parts                 | \$45-\$55            |
| Manufacturing cost/overhead | \$25-\$50            |
| <b>Total:</b>               | <b>\$200-\$295</b>   |

The Consumer Electronics Association (CEA) also had comments in their filing with FCC on April 6, 2001 [FCC, 2001a] that the current prices for DTV tuners are in excess of \$500. The CEA also mentioned in the FCC filing that the electronics package required to receive, decode and display digital television will still command a \$200\* per unit cost premium over required analog circuitry for the foreseeable future, even with the consideration of an aggressive cost reduction curve.

---

\* It is not indicated in the CEA filing with FCC that the \$200 per unit is an incremental manufacturing cost or the cost to consumers, i.e. retail price. Based on the context, we believe this may refer to manufacturing cost.

#### 4.1.3.2 Estimates of Component Costs

To serve as a basis for assessing the likely cost of the components to upgrade sets to include digital capability, several representative integrated circuit components were surveyed.

Table 4-5 summarizes the key characteristics and costs of these components.

**Table 4-5 Representative DTV Components**

| <i>Manufacturer</i>    | <i>Part</i>     | <i>Quantity<br/>(1000s)</i> | <i>Price</i> | <i>Key Features</i>   | <i>Comments</i>  |
|------------------------|-----------------|-----------------------------|--------------|---|--|
| ST<br>Microelectronics | Sti7020         | >50                         | \$35         | <ul style="list-style-type: none"> <li>• Multiple Stream MPEG</li> <li>• HD/SD Decoding</li> <li>• Audio Decoding</li> <li>• 2-D/3-D graphics</li> <li>• NTSC/PAL video encoder</li> <li>• HD/SD video DAC</li> </ul> | Available 4Q2001   |
| Philips                | TDA8961         | 10                          | \$22.5       | <ul style="list-style-type: none"> <li>• Demodulator</li> <li>• Decoder</li> <li>• ATSC</li> <li>• NTSC</li> </ul>  | <ul style="list-style-type: none"> <li>• Target Applications:               <ul style="list-style-type: none"> <li>• Integrated HDTV Receivers</li> <li>• DTV STBs</li> <li>• PC/DTVs</li> </ul> </li> </ul> |
|                        | TDA8980         | 10                          | \$15         | <ul style="list-style-type: none"> <li>• Input processor</li> <li>• ATSC</li> <li>• NTSC</li> </ul>   |  |
| Broadcom               | BCM3510         | 10                          | \$20         | <ul style="list-style-type: none"> <li>• Single Chip Receiver</li> <li>• VSB Demod</li> <li>• ATSC</li> </ul>   |  |
| Texas Instruments      | THS8083<br>A-95 | 1                           | \$15         | <ul style="list-style-type: none"> <li>• Digitizer</li> <li>• A/D</li> <li>• Software Programmable for analog TV or PC graphics</li> </ul>  |  |
| Oren                   | OR51211         | 10                          | \$21         | <ul style="list-style-type: none"> <li>• VSB</li> </ul>   |  |
|                        | OR51221         | 10                          | \$24         | <ul style="list-style-type: none"> <li>• VSB</li> <li>• QAM</li> </ul>  |  |
| NxtWave                | NXT2002         | 10                          | \$20         | <ul style="list-style-type: none"> <li>• 8-VSB</li> </ul>   | Available 1Q2001   |



#### ***4.1.4 Size Distribution of TV Sales***

Based on data acquired on the size distribution of TV receivers sold in the U.S., it is clear that larger sets are, in general, more costly and more feature rich. It follows that sales of these larger sets would be less affected by incremental cost associated with adding a digital TV receiver. The most relevant data were obtained from eBrain Market Research [CEA/eBrain Market Research, 2000]. Their statistics are presented in Table 4-6. As shown, in year 2000, only 16% of color TV (analog) sales were sets of 29 inches or above and 49% were 20 inches or less. The most popular size range was 25 to 27 inches that represented 39% of the market.



It follows that a phased approach could be designed on the basis of screen size to gradually introduce digital technology to the market.

#### 4.1.5 Market Adoption of Related Products

To provide additional perspective on product adoption, data were obtained on related consumer products. Figure 4-5 presented CEA data [Consumer Electronics Association, 2001b] regarding sales of direct view color receivers. These data include both digital and analog direct view color television receivers and, thus, represent a major portion of the total markets in contrast to the digital market estimates presented in Section 4.1.1 of this report.

Figure 4-5 Historical Sales of Color TV Receivers Sales

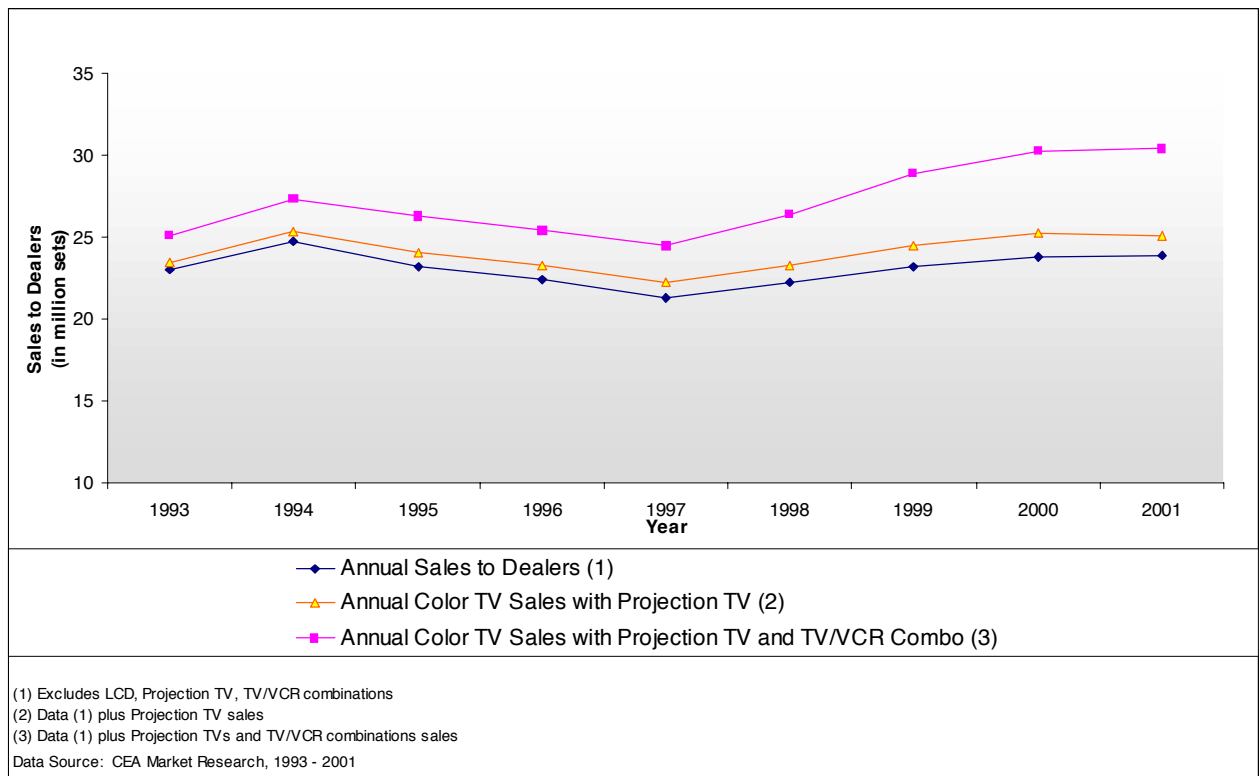

The historical sales data of color TVs are not relevant to predict the adoption of digital TVs, since the former were adopted relatively slowly as they replaced the black and white receivers.

As a second comparison, data for video cassette recorder (VCR) sales were obtained. Figure 4-6 presents these sales [CEA, 2001b] for the period from 1993 to 2001. During this period, VCRs

**Figure 4-6 Historical Sales of Videocassette Recorders (VCR)**

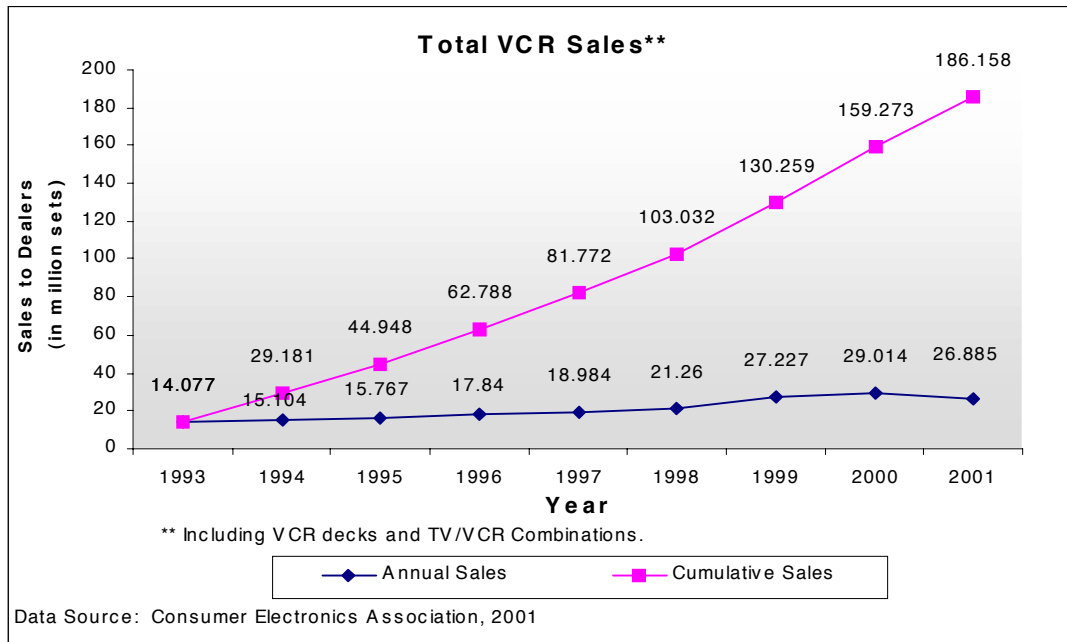

were being rapidly adopted, reaching a current state of near complete penetration into U.S. Households. VCRs represent a much more rapid adoption than did color TV receivers.

As a third comparison, historical subscriber levels for Direct Broadcast Satellite (DBS) services are presented in Figure 4-7 [Carmel Group, 2001b]. At present, DBS service demand is rapidly growing, but is still a relatively small market in comparison to, for example, terrestrial cable services. It was reported that there were about 14.9 million DBS subscribers versus 64.3 million cable subscribers in year 2000 [Carmel Group, 2001a]. This serves to provide a comparison to a currently emerging technology that is beginning to be adopted at a relatively rapid rate.

Figure 4-7 U.S. Direct Broadcast Satellite (DBS) Subscribers

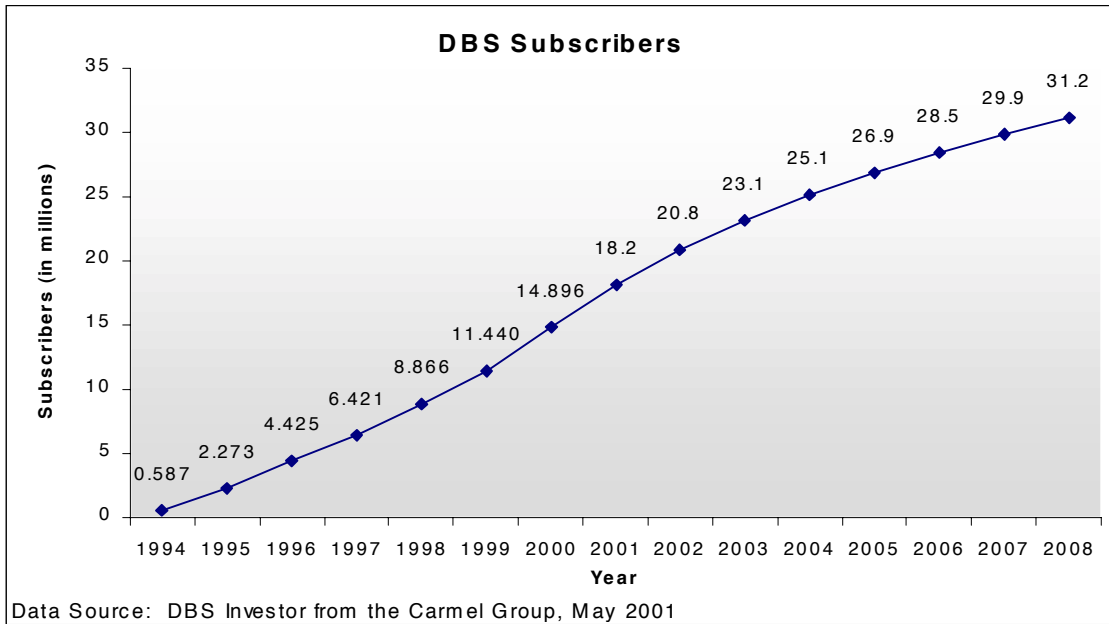

The historical sales data of personal computers (PC) was also considered as relevant to DTV adoption. These data were also obtained from the Consumer Electronics Association [CEA, 2001b] and are presented in Figure 4-8. Personal computers have been rapidly adopted throughout the 1990s but have not become as ubiquitous as television. In comparison with digital TVs, PCs represent a technology that is fairly contemporary and has gone from very low penetration in the early 1990s to widespread penetration at the current date. PCs, however, are a more sophisticated product application and are not likely to offer the universal consumer appeal of advanced television receivers.

Figure 4-8 Historical Sales of Personal Computers

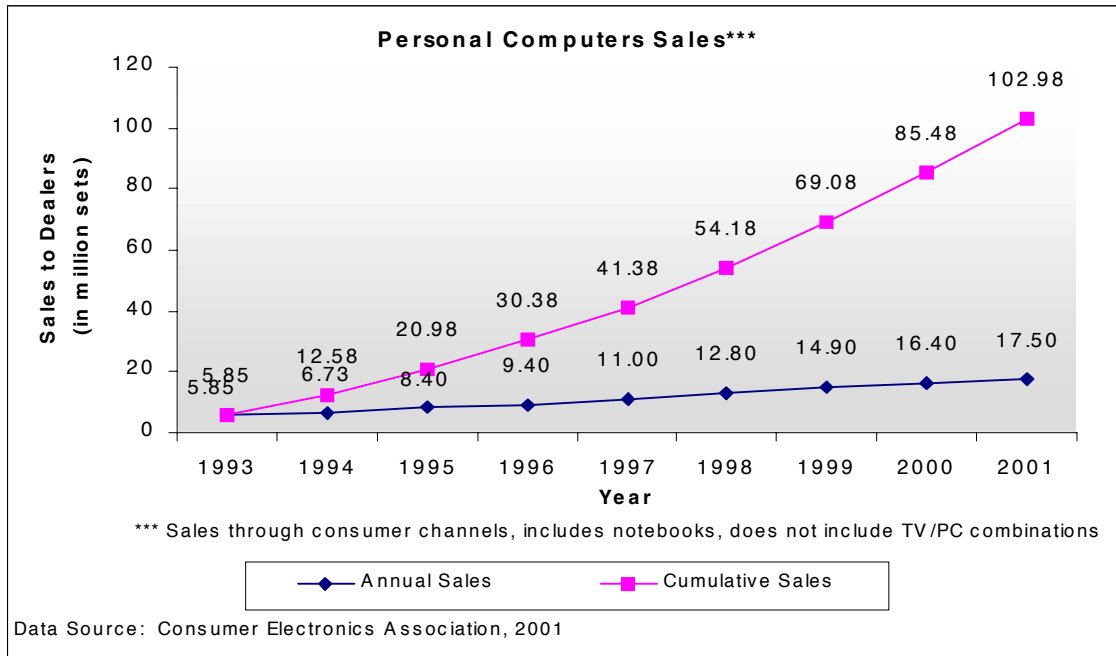

Note that we have computed the cumulative sales numbers for Direct-View color TV receivers, VCRs and Personal Computers for comparison with the penetration of DBS.

#### 4.1.6 Typical Pricing of Conventional Television Receivers

To establish baseline cost estimates for conventional television receivers, we obtained representative pricing at a major Boston area retail store (Tweeter, Etc.). Table 4-7 summarizes these prices as a function of screen size (as of Summer 2001). The data presented are for conventional direct-view NTSC receivers. In general, for the moderate (approximately 25 inch) to large (32 inch and greater) receivers, the prices range from \$270 to approximately \$1000. In a subsequent analysis, a representative price for a small to medium size set was determined to be \$250.

**Table 4-7 Representative Pricing of Conventional Color TV Receivers**

| <b>Typical Price of Conventional NTSC Tube TV Sets by Screen Size</b> |                    |              |
|---|--------------------|--------------|
| <b>Brand</b>  | <b>Screen Size</b> | <b>Price</b> |
| Samsung TXK2567   | 25"                | \$ 269.99    |
| Samsung TXK2767   | 27"                | \$ 299.99    |
| Samsung TXK2768   | 27"                | \$ 349.99    |
| Panasonic CT27D21   | 27"                | \$ 369.99    |
| SONY KV27S42  | 27"                | \$ 399.99    |
| Toshiba 27A60   | 27"                | \$ 429.99    |
| SONY KV27V42  | 27"                | \$ 449.99    |
| Panasonic CT27SX10  | 27"                | \$ 599.99    |
| Sony KV27FS12   | 27"                | \$ 599.99    |
| Samsung TXK3279X  | 32"                | \$ 599.99    |
| Panasonic CT32D31   | 32"                | \$ 649.99    |
| SONY KV32S42  | 32"                | \$ 699.99    |
| Toshiba 32AX60  | 32"                | \$ 699.99    |
| Samsung TXK3679X  | 36"                | \$ 849.99    |
| Toshiba 36AX61  | 36"                | \$ 999.99    |

#### ***4.1.7 Typical Retail Markups for Television Receivers***

Since the data applied in this study include a mixture of retail prices (e.g. TV receiver prices) and component costs (e.g. video integrated circuit prices), it is necessary to understand the relationship between manufacturing costs and the manufacturer prices. To gain insight on this topic, interviews were conducted with a number of knowledgeable manufacturer and industry representatives. In particular, interviews were conducted with representatives of the following organizations:

- RCA/Thomson;
- Zenith/LG Semiconductor;
- Philips/Magnavox; and
- Consumer Electronics Association.

These interviews provided a consensus viewpoint that profit margins (i.e. manufacturer's price relative to manufacturing cost) for a low-end or "leader" model television receiver is in the range of 1.5 to 2.0 times the manufacturing cost. For high-end receivers, higher markups in the range of 2.0 to 2.5 times manufacturing costs may be applied.

Discussion with a leading Boston area retailer (Tweeter, Etc.) revealed that retail markups (i.e. retail price relative to manufacturer's price) are generally about 20% for "leader" models and 35% for higher end sets.

### ***4.1.8 Interview Program***

Following research of public information and the development of initial model-based forecasts, we engaged in a program of interviews with knowledgeable 3<sup>rd</sup> parties to validate our findings and refine our assumptions and models. Interviewees fall into three categories:

- Consumer electronics (CE) manufacturers and manufacturing representatives;
- Integrated circuit supplier of ATSC/DTV chip sets; and
- Consumer electronics retailers.

#### **CE Manufacturers**

Prior to meeting with each stakeholder, we prepared a discussion package which documented our project objectives and initial findings. The package was organized into the following topic areas:

- Objectives of project and the interview
- Overview of project approach and schedule
- Discussion of a reference architecture for a DTV receiver as a basis for a cost model
- Review market demand data
- Review and discuss the current situation for pricing and costs
- Discussion of the initial ADL analysis and underlying assumptions
- Identification and discussion of key issues which might drive costs and timing including:
  - Demand assumptions for shipments and cost sensitivities
  - Cost elements including present and future DTV architectures and trends in key component costs
  - Learning curve theory and assumptions including today's costs, today's volumes, and appropriate learning curve percentage factors
  - Special topics including set-top transverter costs and delta costs for high end versus leader model sets.

Representatives from the following CE manufacturers and manufacturing representatives were interviewed:

- Consumer Electronics Association
- Philips (Magnavox)
- Thomson (RCA)
- Zenith/LG

In all cases the parties interviewed were senior engineering staff directly associated with DTV product R&D and product definition.

The interviews confirmed our modeling methods, general approach, and assumptions but did provide for a significant adjustment in the starting point (i.e. today's incremental costs to enable DTV). In particular the key points of consensus were:



- The starting incremental cost to add a DTV receiver should be in the range of \$100 and not the \$200 or more range suggested by some in responses to the FCC. It was suggested that these higher costs might be appropriate for an HDTV receiver implemented in technology available 1-2 generations ago but that using the reference designs from current IC providers would allow a 480I SDTV implementation at about \$100 incremental material costs. Note that a HDTV receiver would involve additional costs above 480I SDTV for memory, higher speed logic, etc; beyond the additional costs for high resolution display, deflection components, and power supply.
- A manufacturer markup of 1.5X times material cost is typical for a “leader” model set while a factor of 2.0X is typical for a high end receiver.

### **IC Manufacturer**

We researched public information on a number of IC suppliers as further indicated in this report but interviewed only STMicroelectronics (ST) as they had the most recent announcement of next generation DTV chip sets. In particular their STi7020 was announced July 2, 2001 [STMicroelectronics, 2001]<sup>2</sup>. This device provides nearly all the signal processing required to receive ATSC in a single chip.

ST described their reference design for a “leader” model DTV receiver and confirmed that they support the \$100 incremental cost stated by CE manufacturing representatives. In particular, they described their reference design which includes: STi7020 decoder, DTV tuner, VSB decoder, NTSC decoder, multiplexer, memory, and miscellaneous components; with a total cost of about \$101 (including \$35 for STi7020)<sup>3</sup>.

Motorola MCT5100 M-DTV is intended to provide an "add-in" DTV reception capability for existing analog TV set chassis designs. Based on a press release in November 2000, it would be available in the first quarter of 2001 and priced at \$150 in quantities of 100,000.

### **Consumer Electronics Retailers**

We have also collected information from Circuit City and Tweeter Etc. There were a variety of topics covered:

- Current consumer awareness and interest in DTV receivers and set-top boxes
- Current pricing for analog NTSC and DTV-ready low and high end receivers
- Retailer perspectives on consumer price sensitivity and indifference to extra costs for DTV
- Typical retail markup between factory price and retail price

Again we found a strong consensus between the two retailers as well as confirmation on assumptions.

---

<sup>2</sup> See Electronic Engineering Times, July 2, 2001, page 83.

<sup>3</sup> Telephone interview with STM.

The key findings were as follows:

- When a new feature is first introduced, there is an acceptable incremental price consumers would pay for the new feature, for example, the addition of a ‘remote control’ which initially might add \$50 to the sale price of a typical TV. Based on the opinion of the retail store manager that we interviewed, the consumer will pay about an additional \$60 for a DTV receiver in their new TV. This \$60 is considered a level of indifference. There is a belief that even if the consumers could not receive DTV today, they would pay that premium to assure against early obsolescence of their new receiver.
- For leader low-end sets, (versus the most expensive typical TV, or the more expensive high-end TV), the point of indifference is lower than \$60, typically, about 20% of the retail cost. That is, the consumer will tolerate a \$30 premium on a \$150 set to include a digital receiver.
- Some quotes from our interview were as follows:
  - “When 27 inch HDTV sets are available, that will be the set to buy - the threshold for mass market.” [i.e., the market will takeoff. This is based on the size of the average living room and the ratio of screen height to viewing distance]. (from a retail store manager)
  - “People shop for a set based on a specific screen size.” (from a retail store manager)
  - “In general, the lower the price of a set, the lower the margin to all parties” (manufacturer and retailer).
  - Retailer price is \$169 for a 21" Samsung, which includes 19% markup. “The markup on video equipment is lower than that of other consumer electronics equipment, so sales people are encouraged to sell add-ons” (e.g., home theater). (from a retail store manager)
  - “For a high-end receiver, a more typical markup would be 35%.” (from a retail manager)

## **4.2 Key Assumptions**

The data and information described in Section 4.1 are used to derive a number of key assumptions to be applied in the analysis of the cost of widespread enabling of DTV capabilities.

Specifically, the following key observations have been made, based on discussions with industry representatives and review of secondary research on DTV and related markets:

- Adoption occurs in accordance with the Bass Adoption Theory with parameters  $p$  (coefficient of innovation) and  $q$  (coefficient of imitation) similar to those associated with the adoption of color TV technology;
- The analysis is limited to television receivers with 13 inches or larger screens;
- Based on the CEA data[CEA, 2001b], the annual television sales in the U.S. for year 2000 are about 25 million units;

- The initial incremental material cost (as of 2001) to enable DTV reception on a “leader” model NSTC TV is approximately \$100 (we note that this figure of \$100 is about one-half to one-third of the figure expressed by Thomson in their FCC filing [FCC, 2001b], and we support this lower figure based on the research and interview findings in Appendix B);
- Due to limitations in available data, it was necessary to approximate the penetration of DTV technology as the ratio of sales to TV households. This approximation assumes that, over the study period, each sale represents a newly adopting household and that no household retires digital service;
- The US TV households 2001 – 2008 are based on Carmel Group’s forecast [Carmel Group, 2001a]. The subsequent years’ estimates (2009-2015) were forecasted based on the average growth rate of Carmel Group’s previous 8 years forecast numbers.
- The FCC’s “must-carry” rule [47 USC, 2000b; FCC, 1993a & 1994], is still being finalized, and there are several possible outcomes with regard to mandated native 8-VSB carriage for broadcast signals on cable. For the purpose of this report, we assume that consumers will want so called "cable ready" TVs, and that parallel to today's situations, they will want these TVs to demodulate both 8-VSB broadcast signals as well as QAM cable signals. Therefore we assume that the minimal implementation of a SDTV leader model set will be "cable ready" and capable of demodulating both 8-VSB and QAM physical layers;
- The cost to incorporate a DTV receiver in a high-end TV receiver is likely to be lower than that for a low-end model since most high-end receivers include digital signal processing components, such as picture-in-picture and comb filtering.
- In estimating the fraction of TV sets with screens greater than or equal to 32 inches, it was necessary to assume that the market share represented by sets 29 inches and above is approximately the same as the share for sets 32 inches or above (i.e. the relative share of 29 inch screens is negligible). This assumption is required since the available data (i.e. Table 4-6) were presented for 29 inch or larger screens while the phased-mandatory scenario initially affects sets of 32 inch or greater screen size.
- The overall growth in TV sales is assumed to be driven by annual US population growth:
  - The growth rate in TV sales is assumed to be driven by the growth rate in US households which, according to U.S. Census data, averaged 1.65% from 1997 to 1999 [US Census Bureau, 2000];
  - The baseline growth rate in TV sales is assumed to be approximately 1.5% [CEA, 2001b], which is generally consistent with the growth in U.S. households. This rate (1.5%) has been assumed as the overall sales growth in TV sales for purposes of this report;
  - For sensitivity analysis, lower (0.75%) and higher (3%) growth rate scenarios are evaluated.

- The manufacturers' markup factors are 1.5 times and 2.5 times respectively to leader model TV receivers and high-end sets. Retail profit margins are 20% and 35% to leader model and high-end sets respectively. We further assume that set-top box (STB) transverters have the same markup factor and profit margin as those of leader model TV receivers because other advanced features may have been included in the high-end STBs which we do not consider in this study.

These observations, along with the secondary data and interview results are applied in Section 5, Cost Analysis.

## 5 Cost Analysis

### 5.1 Scope of Analysis

To obtain an overall perspective on the rate of DTV adoption and associated economic impact, several adoption scenarios have been considered in this study. In particular, the following scenarios have been selected for analysis:

- Three scenarios:
  - **Baseline Scenario:** Digital TV adoption is driven solely by natural market forces where a consumer's purchase decision is based solely on the benefits of a DTV receiver relative to the additional cost;
  - **Mandate Scenario:** Institution of a government mandate requiring inclusion of a DTV receiver in all sets sold [manufactured] subsequent to a specified future date:
    - Institution of a government mandate that all TV sets 13 inches and above sold after January 1, 2004 should have the capability of receiving digital television;
    - January 1, 2004 is assumed the cut-off date based on the FCC's proposed DTV transition rule which states that, by May 1, 2002, all commercial television stations must commence digital service, and all non-commercial television stations must begin [digital transmission] by May 1, 2003 [FCC, 1997; 47 CFR, 2000]. Under these assumptions, by January 1, 2004, most households should have the ability to access digital television content.
  - **Phased Mandate Scenario:** Institution of a phased government mandate whereby more sophisticated, high-end receivers will be required to include a DTV receiver, and gradually over time, the requirement will be extended to include lower-end models as well:
    - Effective in 2003, all TV sets manufactured with screen sizes 32 inches and above (approximately 19% of total TV sales) must have the capability of receiving digital television;
    - Effective in 2004, all sets with screen sizes 25 inches and larger (summed approximately 56% of total TV sales); must have the capability of receiving digital television;
    - Effective in 2005, all sets having screen sizes 19 inches or above (summed approximately 85% of total TV sales) must have the capability of receiving digital television; and
    - Effective in 2006, all TV sets must have the capability of receiving digital television;
    - This phased mandate scenario is based on the FCC's proposed approach in its *Report and Order and Further Notice of Proposed Rule Making in the Matter of Review of*

*the Commission's Rules and Policies Affecting the Conversion To Digital Television:* "One approach to minimize the impact of such a requirement would be to phase it in over time to take advantage of declining costs associated with electronics manufacturing volumes and apply the requirement initially only to receivers with large screen sizes, e.g. 32 inches and above." [FCC, 2001c].

- Sensitivity analysis on the baseline key assumptions to test the robustness of results to changes in the assumptions has been conducted.

The following sections summarize the approach and results obtained.

## 5.2 Analysis and Methodology

To assess the cost impact related to the inclusion of a DTV receiver, several cost models were developed. These models applied standard mathematical constructs for product penetration and suitable model parameters are estimated from available data and judgement of the project team and industry representatives. In particular, two major components of the model consist of the rate of product adoption and the rates at which component prices are expected to decline as a function of production volume. These effects were modeled using an established theory of product adoption (Bass Theory) and an established model for semiconductor price reduction (Learning Curve Theory) with increases in volume. These central models serve as the basis for the analysis and results presented in this section. The overview of the analysis and methodology are shown in Figure 5-1.

Figure 5-1 Analysis and Methodology Overview

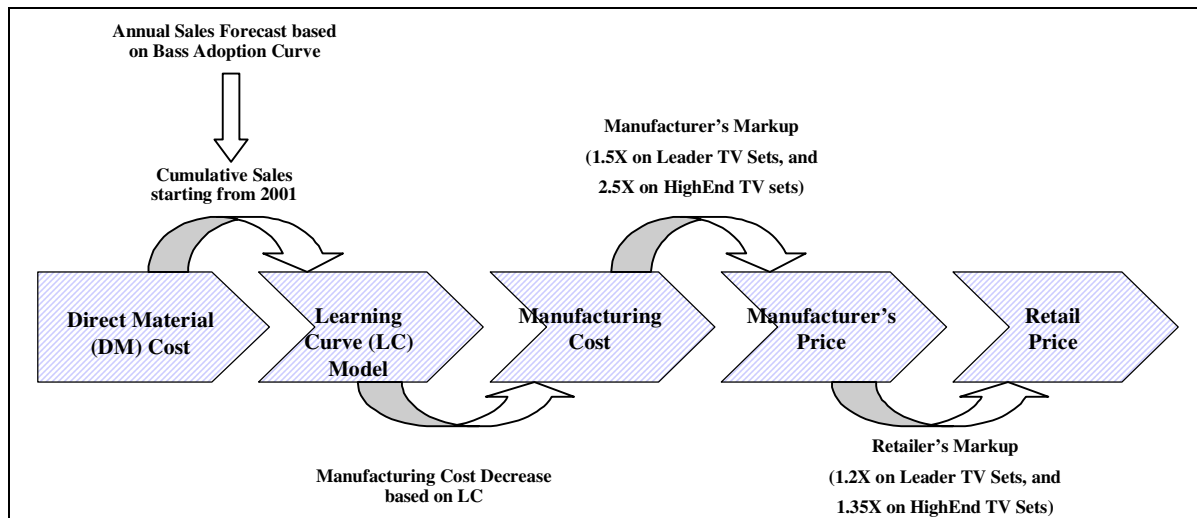

### 5.2.1 Bass Adoption Theory

The Bass Adoption theory is a mathematical model that is well established and accepted for developing estimates of the expected rate of market adoption of new products and technology. It

is based on the fundamental concepts that market adoption is driven by two primary characteristics of the product or technology:

- Innovation – The extent to which the product represents an innovative technology that is useful to consumers “in isolation” regardless of the number of other users adopting the product. Examples might include PDA technology or video recorders which are useful to an individual user who acquires them whether or not his acquaintances also adopt the device;
- Imitation – The extent to which effective use of the product depends on other users also having the product. This dependence can arise either from the device’s intrinsic utility (e.g. two way radios which are useful only if there are other individuals with whom to talk) or from exposure to the product and peer pressure (e.g. electronic devices in “trendy” colors).

The Bass model has been successfully applied to a variety of diverse consumer and industry product adoption processes including:

- Electric Refrigerators;
- Air Conditioners;
- Color Television Sets; and
- Citizen’s Band (CB) Radios.

In the Bass theory, differential equations approximating these effects are developed and solved to yield the following adoption expression [Takada, Hirokazu & Jain, 1991]:

$$F(t) = \frac{1 - e^{-(p+q)t}}{1 + \frac{q}{p} e^{-(p+q)t}} \quad (3.1)$$

Where:

$t$  = Time

$F(t)$  = Fraction of adoptors by time  $t$

$p$  = Coefficient of Innovation

$q$  = Coefficient of Imitation

These expressions for product adoption were applied in the mathematical spreadsheet models used in this analysis. For purposes of this analysis, the innovation and imitation coefficients have been assumed to be those associated with the historical adoption of color television. Specifically, it has been assumed that [Helsen, Jedidi and DeSarbo, 1993]:

$$p = 0.007$$

$$q = 0.357$$

Under these assumptions, the application of the Bass model produces the DTV adoption curve shown in Figure 5-2.

Figure 5-2 Estimated DTV Adoption Curve

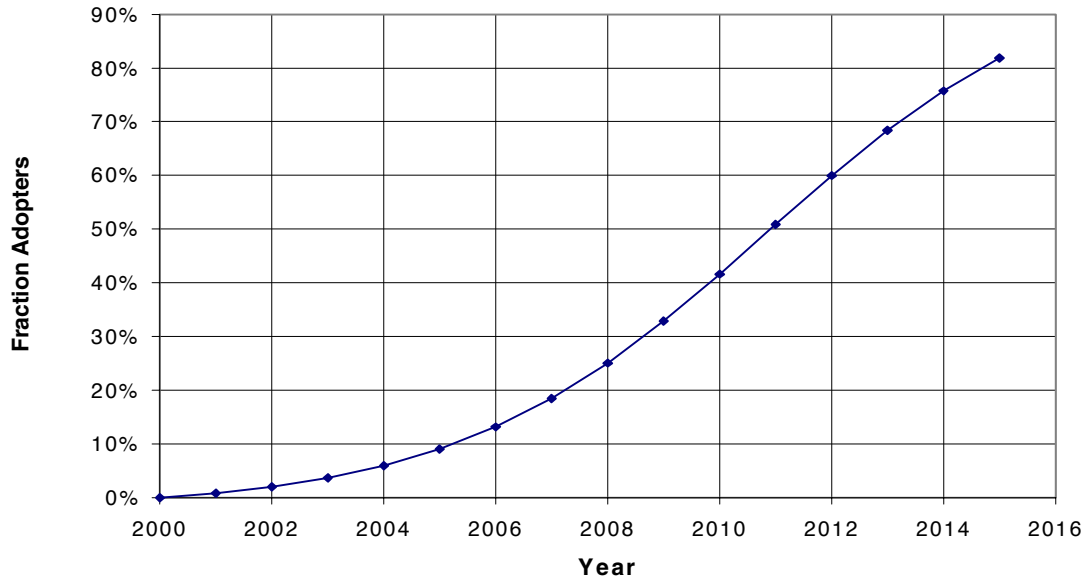

### 5.2.2 Learning Curve Theory

It is well known that the prices of semiconductor devices generally decline with increases in cumulative production [Gruber, 1994]. From this reference, it is noted that a basic learning hypothesis is applicable to a wide range of industries, especially, technologically complex processes. In particular, it is reported to be applicable to the semiconductor industry. The basic concept is that production efficiency improves with experience and results in reduced labor and cost of production. This paper indicates, for example, using the data reviewed that the learning curve factor (Percent cost resulting from a cumulative doubling of volume) ranged from 0.68 to 0.75 for the semiconductor products reviewed. The paper further concludes that regardless of the type of digital integrated circuit that the learning curve factors tend to average about 0.75 learning factor. Therefore for the purposes of this study, it has been assumed that the price of components will be reduced by a factor of 0.75 (i.e. 25% cost reduction) for each doubling of cumulative production. Under this assumption, the cost reduction may be expressed using the following relation:

$$C_t = C_0 \left[ f^{\frac{\ln(V_t/V_0)}{\ln(2)}} \right] \tag{3.2}$$

Where:



$t$  = time

$C_t$  = Cost at time  $t$

$V_t$  = Sales Volume at time  $t$

$f$  = Fraction of original cost resulting from doubling cumulative volume

Applying this model, the manufacturing learning curve in Figure 5-3 is obtained for the Baseline (free market adoption) Scenario. Industry representatives, with whom we discussed these results, were in general agreement with the levels of cost reduction predicted.

**Figure 5-3 Estimated Component Cost Learning Curve (Percent - Baseline Scenario)**

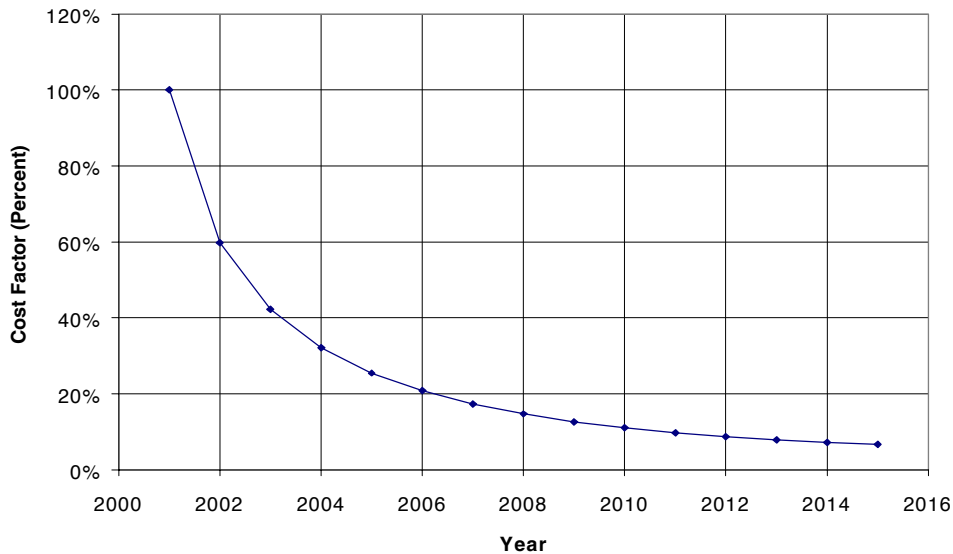

These curves are assumed in the subsequent analysis.

### **5.3 Integrated Leader Model DTV**

The focus of this study is on integrated digital TV receivers. In this section, the integrated DTV analysis is presented for a leader model (i.e. Case A in Figure 3-1) SDTV for each of the three scenarios.

#### **5.3.1 Baseline Scenario: Free Market Adoption**

In the baseline scenario, adoption of DTV technology is assumed to be driven solely by market forces without governmental intervention. In this case, the market dynamics are approximated by adoption according to the Bass Theory, and incremental costs begin at \$100 per TV set and decline according to the learning curve presented in Section 5.2.2. of this report.

### 5.3.1.1 Baseline Sales Forecast

Assuming the year 2000 television sales in the U.S. represent 25 million units, we apply a 1.5% annual TV sales growth rate and adopting the assumptions and models presented above leads to the DTV sales forecast presented in Figure 5-4.

Figure 5-4 Baseline U.S. Sales Forecast for DTV

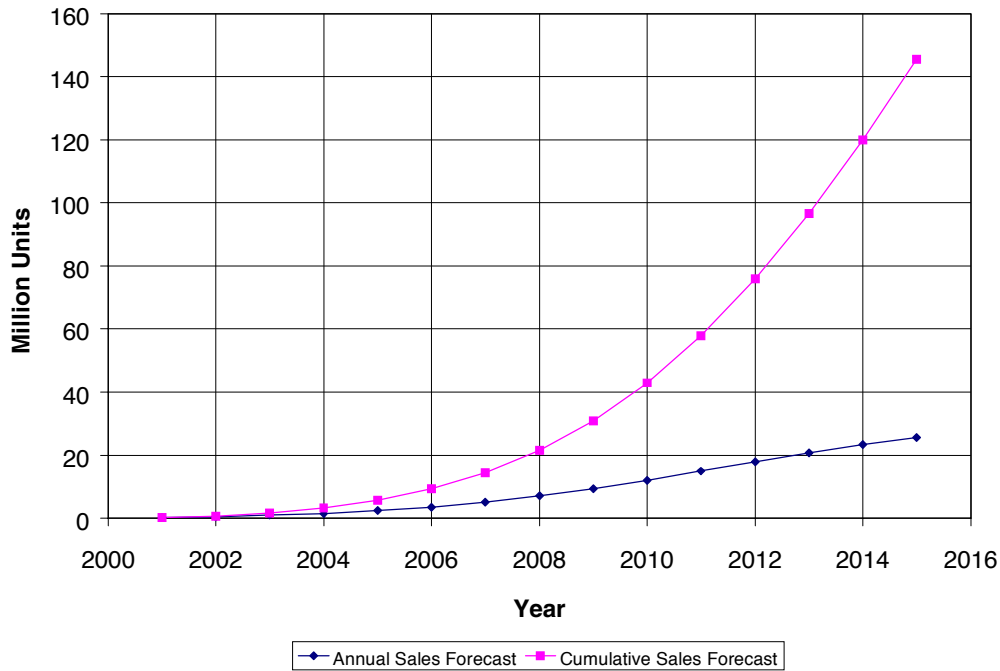

In this model, the cumulative DTV sales under the free market adoption scenario are predicted to reach almost 9.3 million sets by Year 2006. Assuming the Carmel Group's TV household forecast number 109.3 million in year 2006 [Carmel Group, 2001a], the 2006 DTV penetration would be approximately 8.5%. Under these assumptions, 85% household adoption rate would not be realized probably until 2014.

Given the assumed learning curve, the incremental material cost would, under these assumptions, decrease from \$100 to approximately \$21 by year 2006. See Figure 5-5 below.

Figure 5-5 Assumed Cost Learning Curve for Components (Cost – Baseline Scenario)

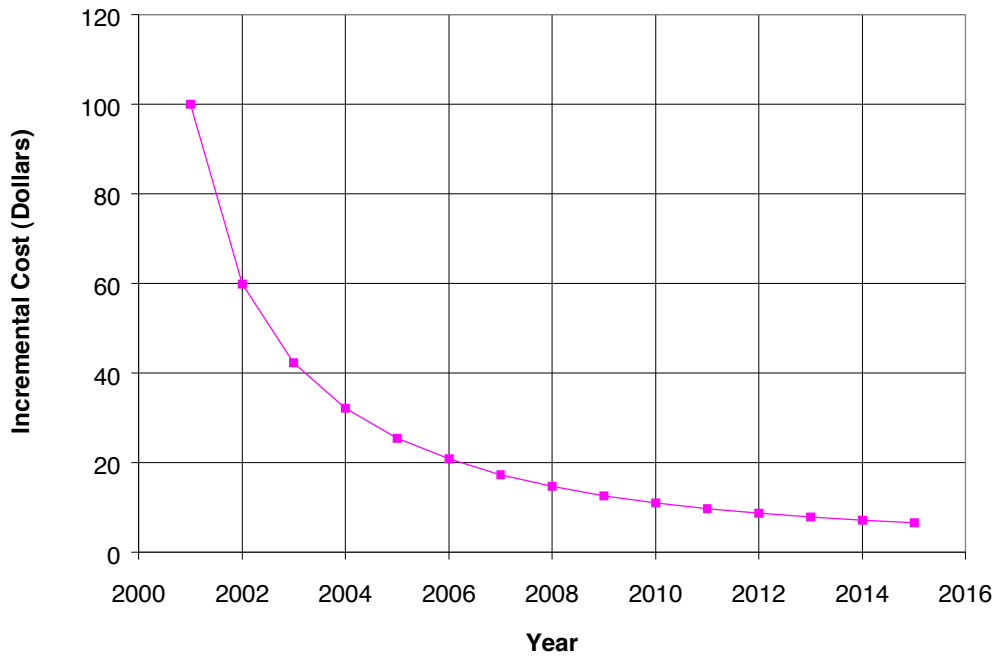

The Figure 5-6 illustrates the DTV sales forecast and cost learning curve combined under the baseline case scenario over study period. As shown, the cumulative DTV sales increase from 0.21 million in 2001 to 9.3 million in 2006; while the incremental cost declines from \$100 to \$21 per set in the same time frame.

**Figure 5-6 Baseline DTV Sales Forecast and Cost Learning Curve**

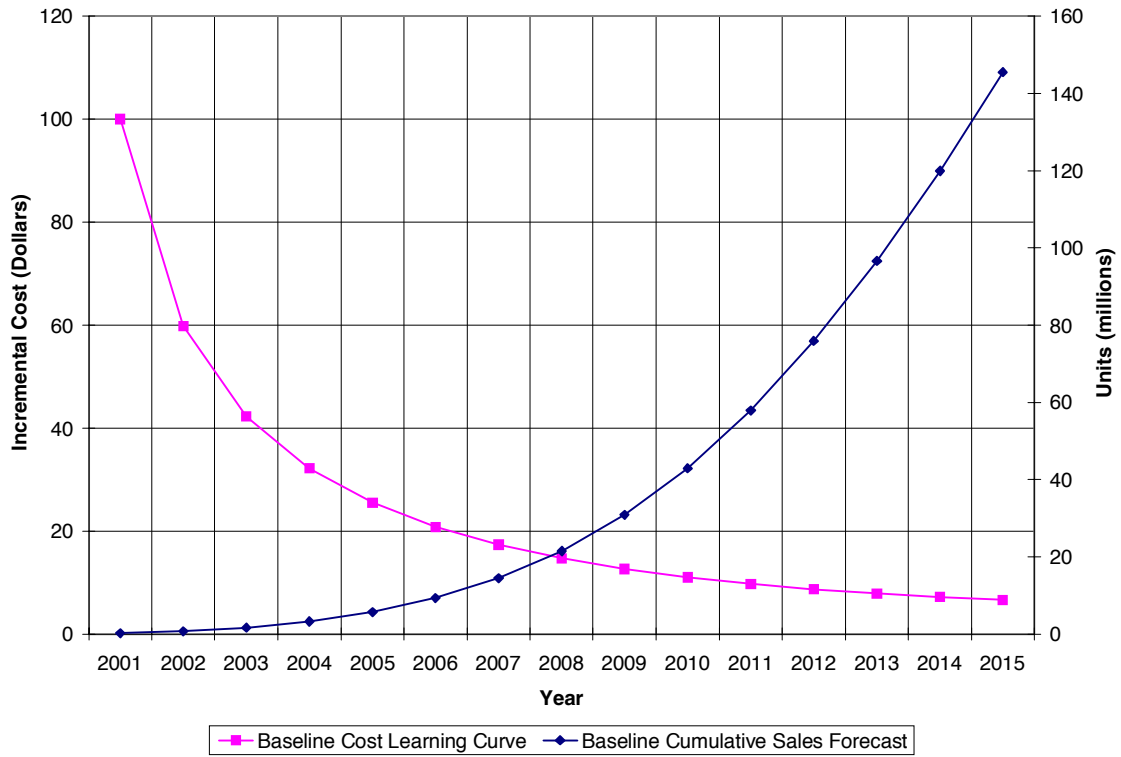

**5.3.1.2 Predicted Effect on Manufacturer and Retail Pricing**

By applying a 1.5 markup factor to direct material cost and a 1.2 markup for retail margin, the price impact curve in Figure 5-7 is derived.

**Figure 5-7 Estimated Impact on Manufacturer and Retail Price**

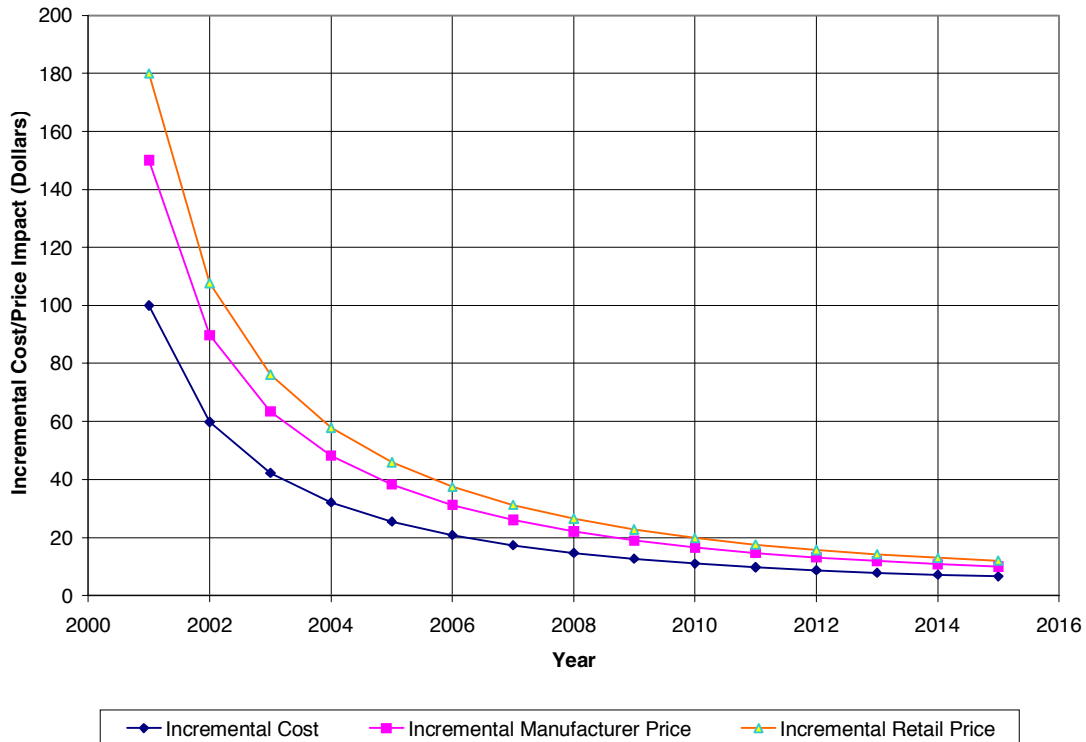

Based on the assumed markups and models, the incremental retail price associated with inclusion of a DTV receiver would initially be \$180 and would decline to approximately \$38 by year 2006.

### 5.3.1.3 Impact on Manufacturer Price and Retail Price with 1 Year Forward Pricing

Under the assumption that manufacturers adopt a 1-Year Forward Pricing strategy, the price impact curve presented in Figure 5-8 is obtained.

As shown in Figure 5-8, a 1-year Forward Pricing strategy would result in a dramatic reduction in the estimated retail price. This is particularly true in the initial years. For example, in year 2001, the estimated price decreases from \$180 to \$108, i.e. a 41% decrease under this assumption. As for 2004, the estimated price would decrease from \$58 to \$46, a 21% decrease.

Please note that the forward pricing has the same impact on retail pricing under the FCC mandate scenarios which we will discuss later in Section 5.3.4 and 5.3.5 of the report.

**Figure 5-8 Estimated Impact on Manufacturer and Retail Price Assuming 1-Year Forward Pricing**

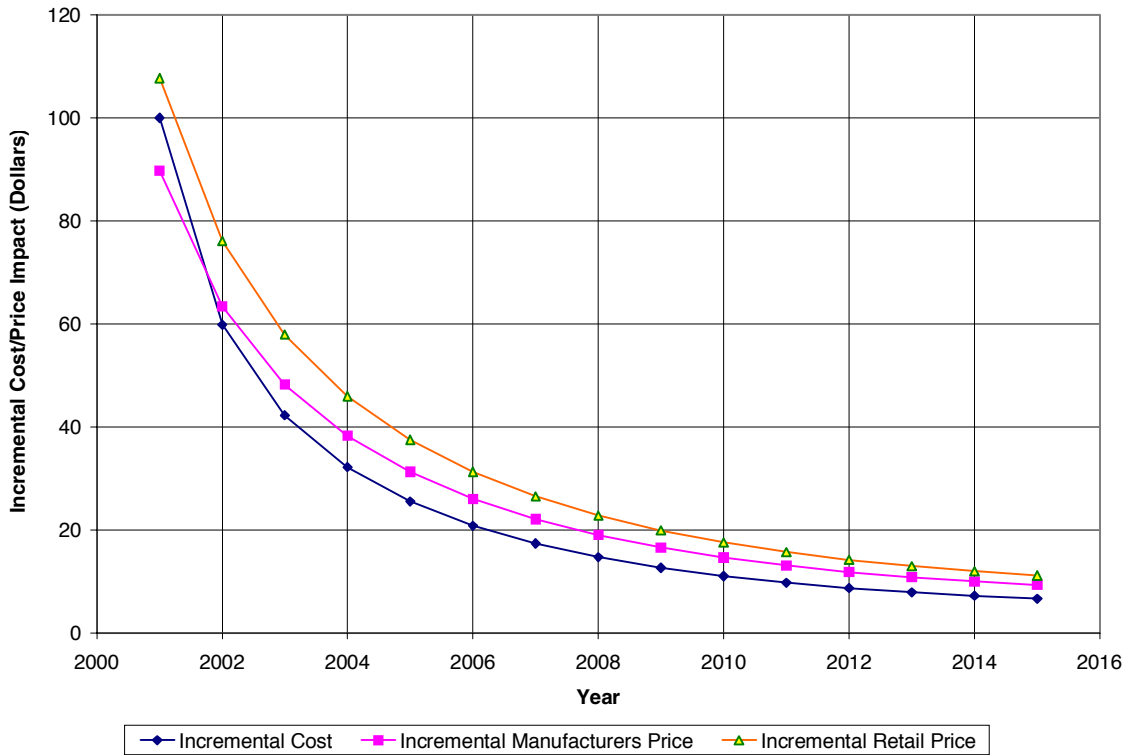

### 5.3.2 Sensitivity Analysis

To explore the dependence of the conclusions on key assumptions, the model results are presented under variations in the assumed annual TV sales, TV sales growth rate and incremental material cost.

#### 5.3.2.1 Variance in annual TV Sales in Year 2000

If we include 5 million extra TV/VCR combination sales in year 2000 [CEA, 2001b], or about 20% increase from the above 25 million annual TV sets sales as we assumed above, the total annual TV sales will therefore be 30 million in 2000. Keeping all the other assumptions the same, the impact on our DTV sales and market share forecast under the three scenarios is shown in Figure 5-9 and summarized as follows:

**Figure 5-9 DTV Sales and Market Share Forecast under 30 million v.s. 25 million Annual TV Sales in 2000**

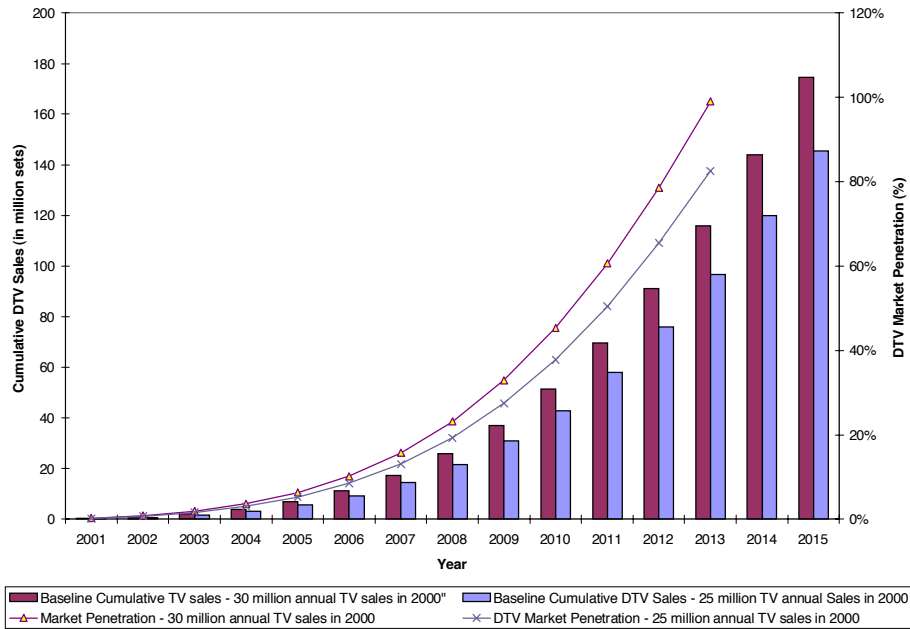

- **DTV Sales:**

The cumulative DTV sales would increase by 20% for each year under 30 million annual TV sales assumption in year 2000. For example, the first year 2001 DTV sales will increase from previous 0.21 million sets to 0.25 million, a 20% increase. The cumulative DTV sales in 2006 would be 11.16 million vs. 9.6 million sets, also a 20% increase. The reason is that we have applied the same Bass Adoption rate for each year, which is decided by the same parameters, on the annual TV sales for each year.

- **Market Penetration:**

Assuming the US TV households maintain the same in the two annual TV sales cases, the 20% increase on DTV sales each year will increase the DTV market penetration rate accordingly. As of year 2006, the DTV market penetration would increase from 8.5% to 10.2% under the new assumptions. The 85% target market penetration rate will be reached in 2013, one year earlier than in the previous case.

- **Incremental Cost and Prices:**

The incremental cost will be the same under these two annual TV sales cases, since the cumulative sales increase at the same rate by year, the doubling rate in our learning curve would be the same, too. If we maintain the same retail markup, the retail price increases would maintain the same under new annual TV sales assumption.

### 5.3.2.2 Variance in Annual Sales Growth

To examine sensitivity to the growth rate assumption, the model was run for low (0.75%), medium (1.5%) and high (3%) growth rate cases for annual TV sales. This results in the results presented in Figure 5-10 for annual sales projections and Figure 5-11 for cumulative sales projections.

**Figure 5-10 Estimated Adoption of DTV versus Assumed Growth Rate Scenario**

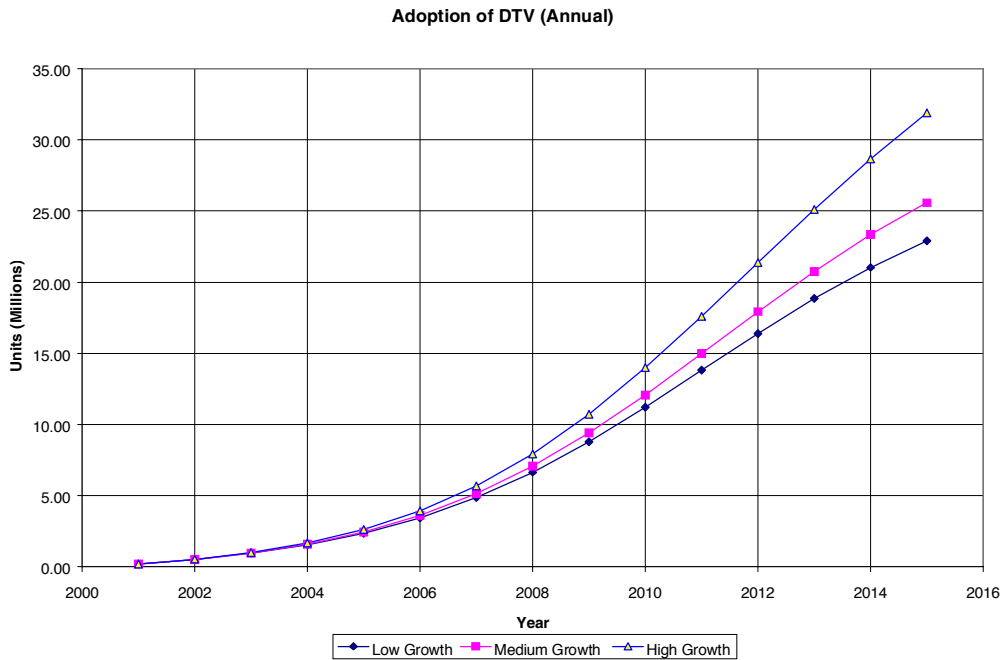

Considering low and high growth rate assumptions, the cumulative DTV sales forecast would range from 9 million to 10 million in 2006 under the baseline free market adoption scenario. Assuming 109.3 million TV households [Carmel Group, 2001a], estimated DTV penetration rates range from 8% to 9%. Thus, the FCC's 85% target adoption objective would not be realized until 2013, even under the high sales growth rate assumption.



**Figure 5-11 Projected Cumulative Sales versus Growth Rate**

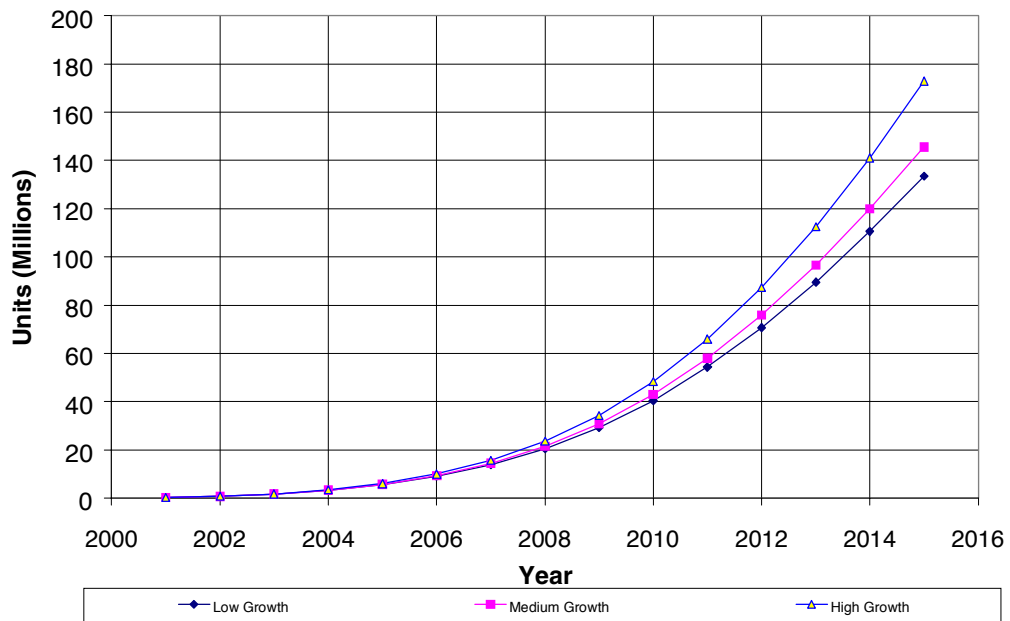

### 5.3.2.3 Variance in Incremental Cost

Assuming a range of incremental cost assumptions (low (\$80), medium (\$100) and high (\$150)) for incorporation of a DTV receiver in newly manufactured consumer TV sets, the cost projections of Figure 5-12 are obtained. The DTV incremental cost as of 2006 would be in the range of \$16.7 to \$31.3 per TV set.

**Figure 5-12 Projected Unit Cost versus Assumed Initial Incremental Cost**

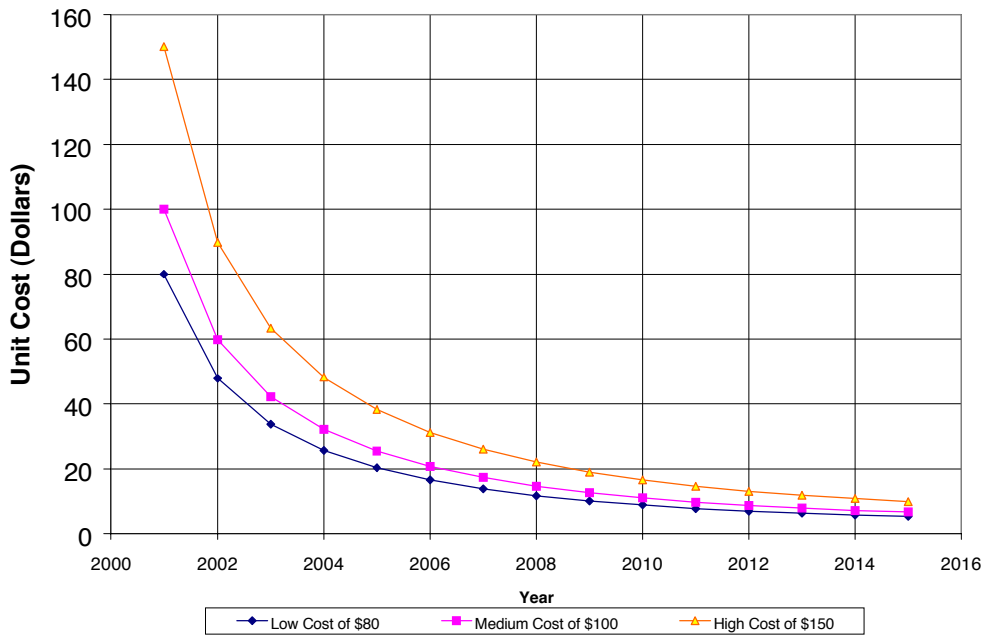

Considering the effects of the assumed markups, the estimated impact on manufacturer price is as shown in Figure 5-13. Also introducing the assumed retail price markup results in the estimates presented in Figure 5-14.

**Figure 5-13 Estimated Impact on Incremental Manufacturer's Price versus Assumed Initial Incremental Cost**

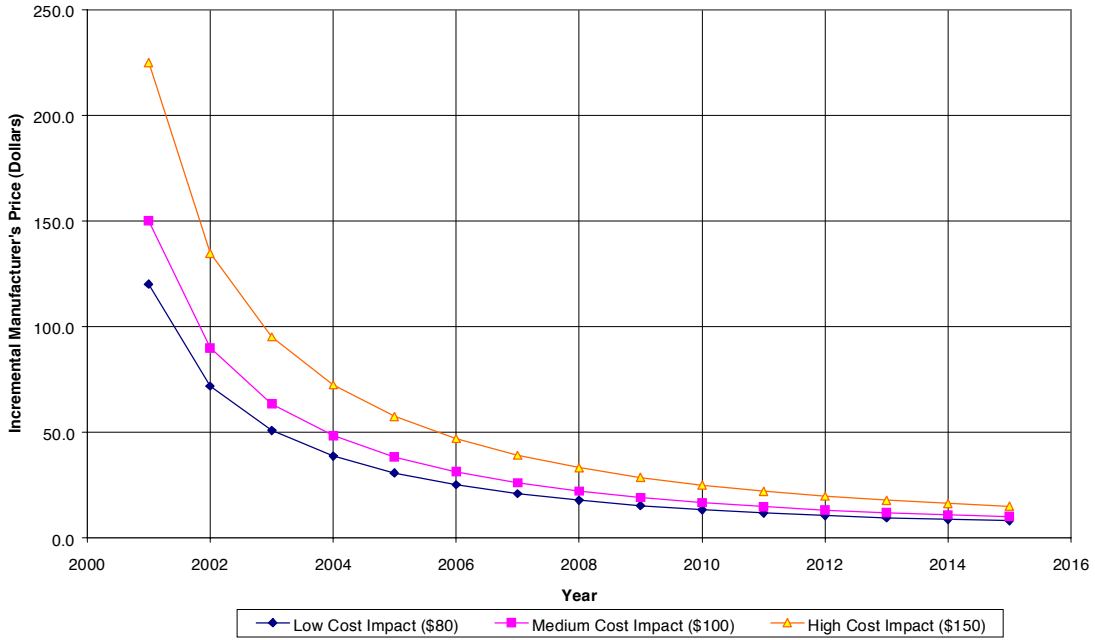

**Figure 5-14 Estimated Impact on Retail Price versus Assumed Incremental Cost**

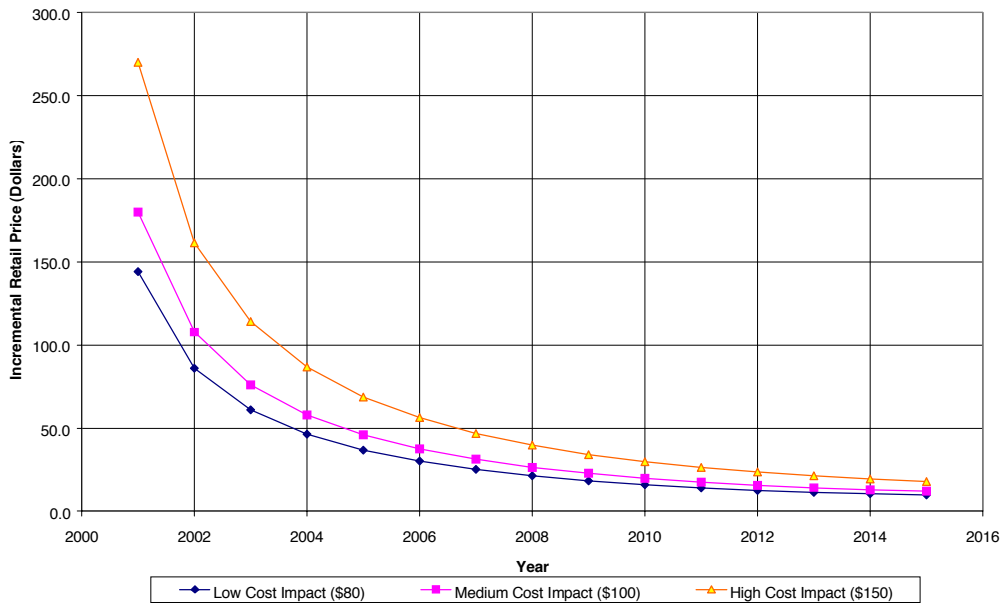

The effect of varying the initial direct material cost (\$80, \$100 or \$150) results in incremental retail price would be from \$30 to \$56 in year 2006. If a forward pricing policy were assumed, the predicted effect on retail price would be smaller.

Assuming the average analog TV retail price is about \$250 over the study period, the retail price increase in percentage related to adding a DTV receiver under different cost scenarios are shown in Figure 5-15. The initial percentage increase may be high, especially under high incremental cost (\$150) scenario, however, these percentages will quickly drop to 12%-23% in year 2006, close (or within) the 20% “customers indifference” as suggested by the retailer manager of a leading consumer electronics [Tweeter etc., 2001].

**Figure 5-15 Baseline Case Retail Price Increase Percentage**

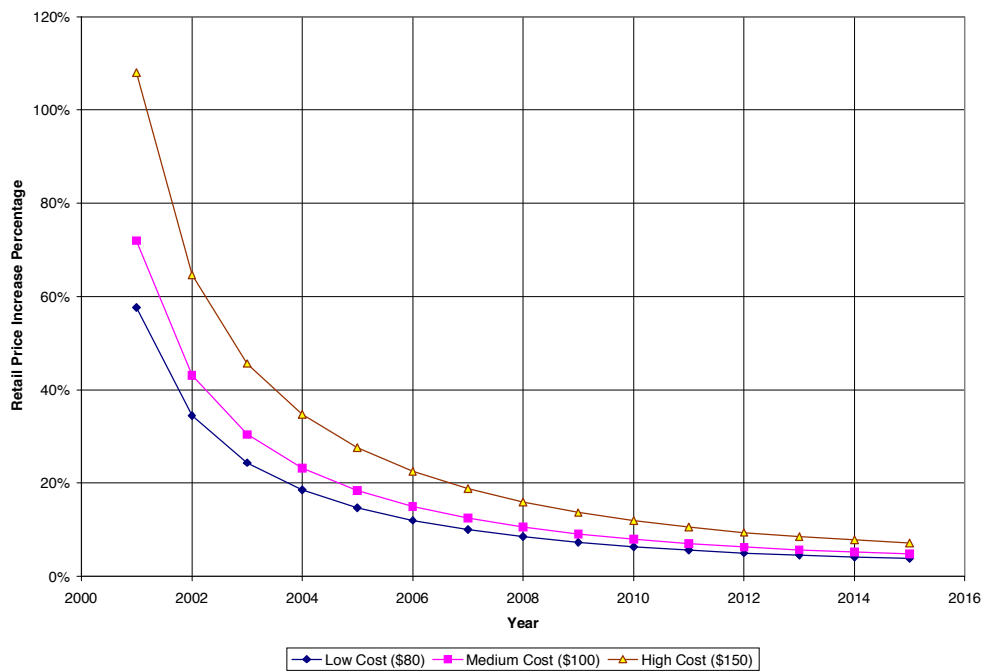

### 5.3.3 Summary of Baseline Analysis

Table 5-1 summarizes the results of the Baseline Scenario (free market adoption scenario).

**Table 5-1 Summary of Results for Baseline Scenario**

| Year | Annual DTV Sales (million units) | Cumulative DTV Sales (million units) | Incremental Cost/Unit (\$) | Incremental Retail Price/Unit (\$) | US TV Households | US Household DTV Penetration Rate |
|------|----------------------------------|--------------------------------------|----------------------------|------------------------------------|------------------|-----------------------------------|
| 2001 | 0.21                             | 0.21                                 | 100                        | 180                                | 104.0            | 0.2%                              |
| 2002 | 0.52                             | 0.73                                 | 60                         | 108                                | 105.0            | 0.7%                              |
| 2003 | 0.96                             | 1.69                                 | 42                         | 76                                 | 106.0            | 1.6%                              |
| 2004 | 1.58                             | 3.27                                 | 32                         | 58                                 | 107.1            | 3.1%                              |
| 2005 | 2.44                             | 5.71                                 | 26                         | 46                                 | 108.2            | 5.3%                              |
| 2006 | 3.60                             | 9.30                                 | 21                         | 38                                 | 109.3            | 8.5%                              |
| 2007 | 5.13                             | 14.43                                | 17                         | 31                                 | 110.3            | 13.1%                             |
| 2008 | 7.06                             | 21.49                                | 15                         | 26                                 | 111.4            | 19.3%                             |
| 2009 | 9.40                             | 30.89                                | 13                         | 23                                 | 112.5            | 27.5%                             |
| 2010 | 12.08                            | 42.97                                | 11                         | 20                                 | 113.6            | 37.8%                             |
| 2011 | 14.98                            | 57.94                                | 10                         | 18                                 | 114.8            | 50.5%                             |
| 2012 | 17.92                            | 75.87                                | 9                          | 16                                 | 115.9            | 65.4%                             |
| 2013 | 20.75                            | 96.62                                | 8                          | 14                                 | 117.1            | 82.5%                             |
| 2014 | 23.32                            | 119.94                               | 7                          | 13                                 | 118.3            | N/A                               |
| 2015 | 25.57                            | 145.51                               | 7                          | 12                                 | 119.4            | N/A                               |

As Table 5-1 shows, the first year DTV sales is about 0.21 million sets in 2001, with incremental manufacturing cost of \$100. The shaded entries highlight the key figures for the year 2006 when the FCC plans to achieve its target of 85% penetration. As shown, the cumulative sales are projected to be in the vicinity of 9.3 million units at an incremental retail price of \$38 in 2006. Relative to a projected installed base of 109.3 million TV households [Carmel Group, 2001a], this corresponds to a penetration of 8.5 percent, which is well below the target penetration. Please note that as we mentioned in Section 4.2 Key Assumptions, due to limitations in available data, we have assumed the penetration rate of DTV technology as the ratio of DTV sales to US TV households. We do not include penetration rates in 2014 and 2015 since multiple DTV sales to one household may happen starting in those years.

### **5.3.4 Mandate Scenario**

In this scenario, it is assumed that the FCC issues a mandate to incorporate a digital TV receiver in all sets sold [manufactured] as of a specified date. For purposes of this analysis, it is assumed that the date for mandatory implementation is January 1, 2004. All other analysis assumptions are the same as for the Baseline Scenario presented in Section 5.3.1. of this report.

Applying these assumptions to the cost model yields the sales and cost projections presented in Figure 5-16 and Figure 5-17.

**Figure 5-16 Projected Unit Sales under Government Mandate Scenario**

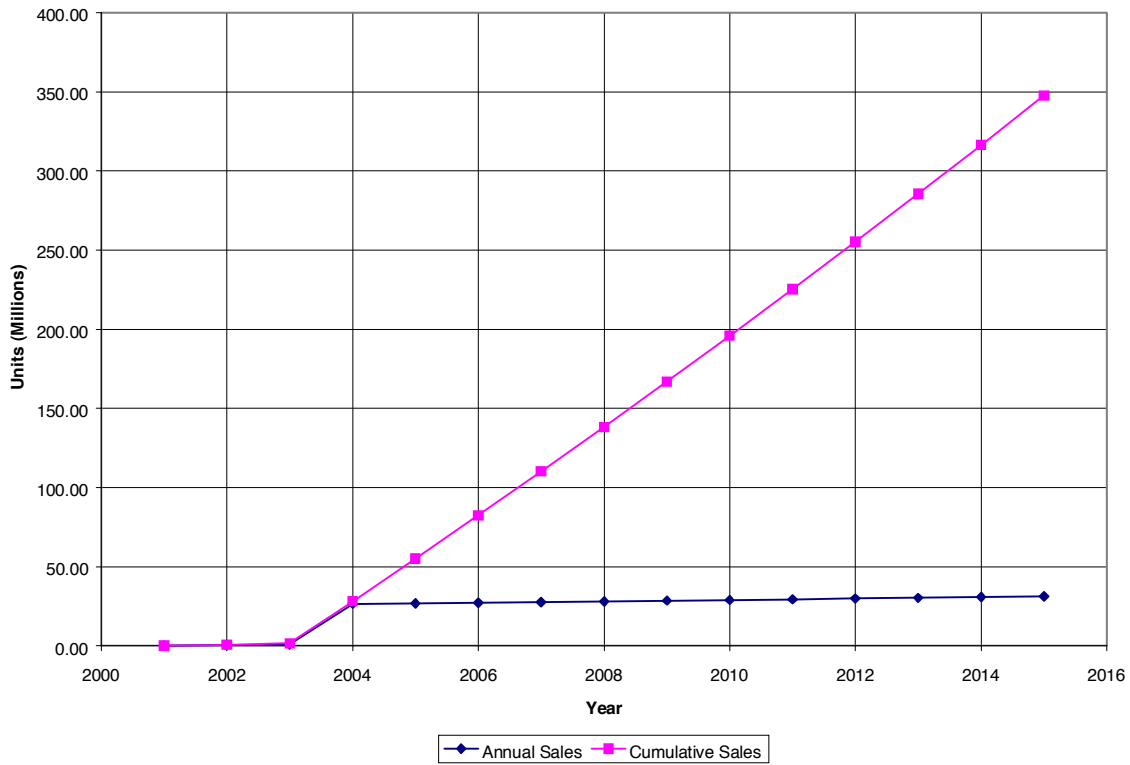

**Figure 5-17 Estimated Impact on Cost and Price under FCC Mandate Scenario**

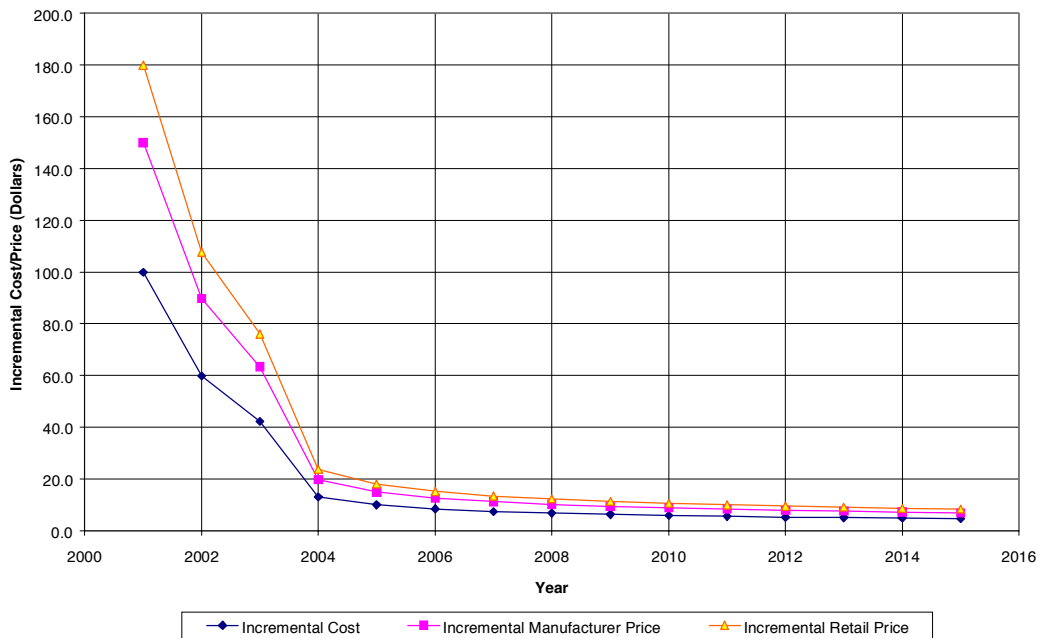

As shown in Figure 5-16, assuming an FCC “cut-off date mandate”, the estimated cumulative DTV sales would reach 82.5 million units in 2006. Assuming that in 2006, the number of U.S. TV owning households is approximately 109.3 million [Carmel Group, 2001a], the DTV household penetration rate would be 82.5/109.3 or 75.5%. In this scenario, the FCC’s 85% target penetration rate is realized in 2007.

From this analysis, it is seen that the estimated incremental price falls more rapidly than in the baseline scenario due to the increase in DTV sales resulting from the government mandate. Specifically, the cost is projected to decrease from \$100 in 2001 to \$8.4 in 2006. The corresponding increment in retail price would also decrease to \$15 by 2006. This is a substantial reduction over the 2006 cost and price estimates of \$21 and \$38 that were respectively projected for the baseline scenario.

#### 5.3.4.1 Summary of Results for FCC Mandate Scenario

The results of the analysis for the FCC mandate scenario are shown in Table 5-2.

**Table 5-2 Summary of Results for FCC Mandate Scenario**

| Year | Annual DTV Sales (million units) | Cumulative DTV Sales (million units) | Incremental Cost/Unit (\$) | Incremental Retail Price/Unit (\$) | US TV Households* | US Household DTV Penetration Rate |
|------|----------------------------------|--------------------------------------|----------------------------|------------------------------------|-------------------|-----------------------------------|
| 2001 | 0.21                             | 0.21                                 | 100.0                      | 180.0                              | 104.0             | 0.2%                              |
| 2002 | 0.52                             | 0.73                                 | 59.8                       | 107.7                              | 105.0             | 0.7%                              |
| 2003 | 0.96                             | 1.69                                 | 42.3                       | 76.1                               | 106.0             | 1.6%                              |
| 2004 | 26.53                            | 28.23                                | 13.1                       | 23.7                               | 107.1             | 26.4%                             |
| 2005 | 26.93                            | 55.16                                | 10.0                       | 17.9                               | 108.2             | 51.0%                             |
| 2006 | 27.34                            | 82.49                                | 8.4                        | 15.2                               | 109.3             | 75.5%                             |
| 2007 | 27.75                            | 110.24                               | 7.5                        | 13.4                               | 110.3             | 99.9%                             |
| 2008 | 28.16                            | 138.40                               | 6.8                        | 12.2                               | 111.4             | N/A                               |
| 2009 | 28.58                            | 166.99                               | 6.3                        | 11.3                               | 112.5             | N/A                               |
| 2010 | 29.01                            | 196.00                               | 5.9                        | 10.6                               | 113.6             | N/A                               |
| 2011 | 29.45                            | 225.45                               | 5.5                        | 10.0                               | 114.8             | N/A                               |
| 2012 | 29.89                            | 255.34                               | 5.3                        | 9.5                                | 115.9             | N/A                               |
| 2013 | 30.34                            | 285.68                               | 5.0                        | 9.1                                | 117.1             | N/A                               |
| 2014 | 30.79                            | 316.47                               | 4.8                        | 8.7                                | 118.3             | N/A                               |
| 2015 | 31.26                            | 347.73                               | 4.6                        | 8.3                                | 119.4             | N/A                               |

In Table 5-2, the shaded rows highlight the key figures for 2004, the year proposed for the introduction of a mandate and 2006, the target year to realize 85% TV household penetration. As shown, the TV household penetration in 2006 will be 75.5% under this scenario, assuming that each DTV sale corresponds to a new household adopting DTV. Again, we do not include the penetration rates for 2008 and later due to higher DTV sales would lead to multiple sales to one household.

### 5.3.5 Phased-Mandate Scenario

The final scenario considered assumes a phased-mandate starting in year 2003 requiring sets 32 inches and larger to be capable of receiving digital television, and expanding the mandate over time to include smaller sets until it covers all receivers by 2006. The resulting estimates of DTV adoption are presented in Figure 5-18.

Figure 5-18 Estimated DTV Adoption under Mandatory Phased Scenario

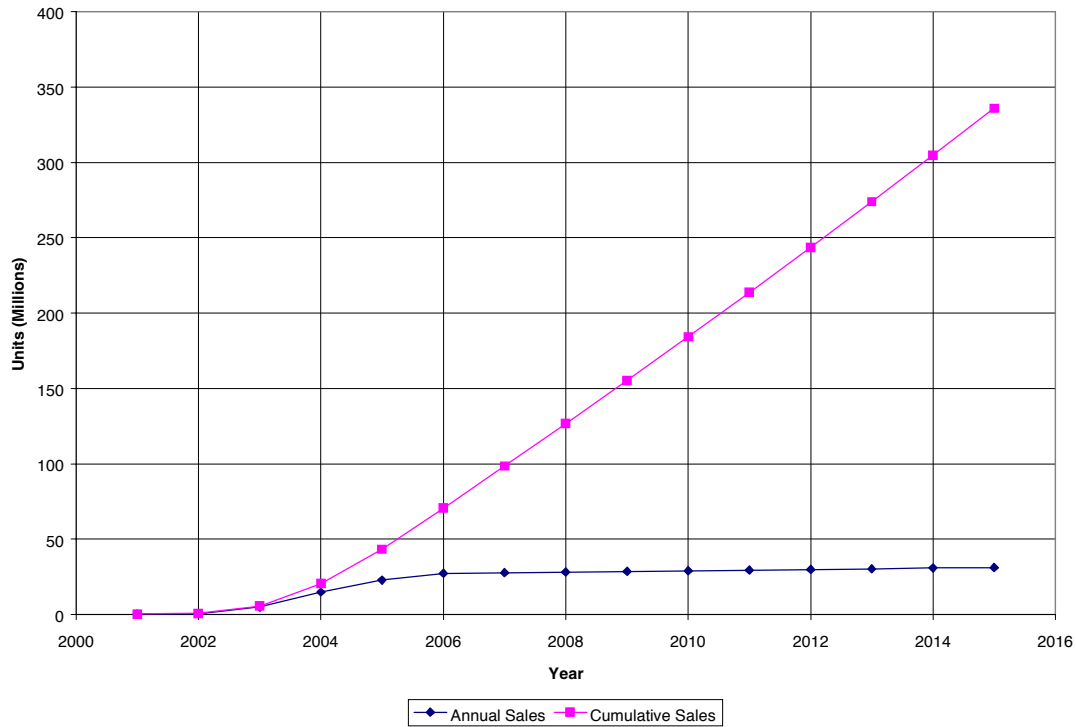

In this scenario, the cost curve and the corresponding manufacturer/retail price estimates are as presented in Figure 5-19.



**Figure 5-19 Estimated Cost and Price Impact under Mandatory Phased Scenario**

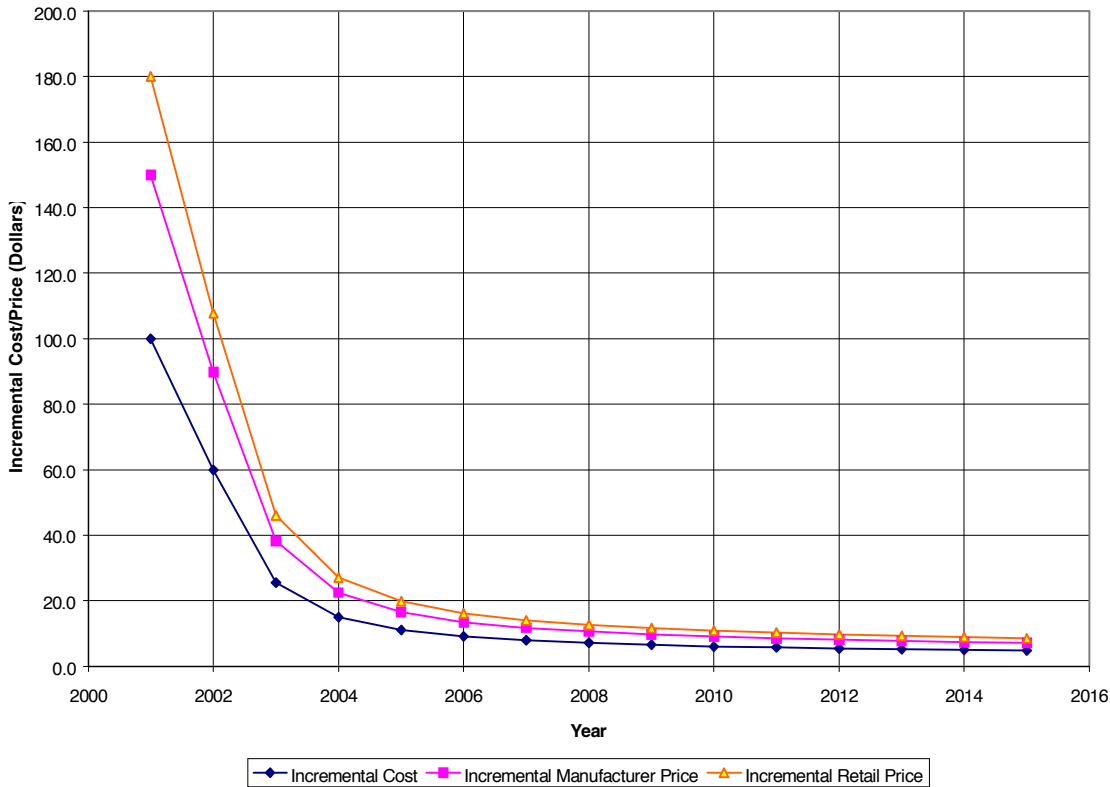

Assuming the FCC institutes a mandate for phased DTV implementation, the cumulative DTV sales are projected to reach nearly \$70.8 million in year 2006. Based on an assumption of 109.3 million U.S. households owning TV sets in 2006 [Carmel Group, 2001], the DTV household penetration rate would be 65% which is lower than the FCC's 85% target penetration for that date. The target penetration rate is reached by 2007 under this scenario.

In this scenario, the incremental cost of implementation is projected to decrease from \$100 in 2001 to \$9 in 2006. The corresponding incremental retail price would be approximately \$16 in 2006.

### **5.3.5.1 Summary of Results for Phased Mandate Scenario**

The results obtained for the mandatory phased implementation of DTV are presented in Table 5-3.

**Table 5-3 Summary of Results for FCC Phased Mandate Scenario**

| Year | Phased-in Schedule | Annual DTV Sales (million units) | Cumulative DTV Sales (million units) | Incremental Cost/Unit (\$) | Incremental Retail Price/Unit (\$) | US TV Households* | US Household DTV Penetration Rate |
|------|--------------------|----------------------------------|--------------------------------------|----------------------------|------------------------------------|-------------------|-----------------------------------|
| 2001 | N/A                | 0.21                             | 0.21                                 | 100.00                     | 180.0                              | 104.0             | 0.2%                              |
| 2002 | N/A                | 0.52                             | 0.73                                 | 59.84                      | 107.7                              | 105.0             | 0.7%                              |
| 2003 | All 32" & above    | 4.97                             | 5.70                                 | 25.53                      | 46.0                               | 106.0             | 5.4%                              |
| 2004 | All 25" & above    | 14.86                            | 20.56                                | 14.99                      | 27.0                               | 107.1             | 19.2%                             |
| 2005 | All 19" & above    | 22.89                            | 43.45                                | 10.99                      | 19.8                               | 108.2             | 40.2%                             |
| 2006 | All 13" & above    | 27.34                            | 70.79                                | 8.97                       | 16.2                               | 109.3             | 64.8%                             |
| 2007 | N/A                | 27.75                            | 98.53                                | 7.82                       | 14.1                               | 110.3             | 89.3%                             |
| 2008 | N/A                | 28.16                            | 126.70                               | 7.05                       | 12.7                               | 111.4             | N/A                               |
| 2009 | N/A                | 28.58                            | 155.28                               | 6.48                       | 11.7                               | 112.5             | N/A                               |
| 2010 | N/A                | 29.01                            | 184.29                               | 6.03                       | 10.9                               | 113.6             | N/A                               |
| 2011 | N/A                | 29.45                            | 213.74                               | 5.67                       | 10.2                               | 114.8             | N/A                               |
| 2012 | N/A                | 29.89                            | 243.63                               | 5.37                       | 9.7                                | 115.9             | N/A                               |
| 2013 | N/A                | 30.34                            | 273.97                               | 5.12                       | 9.2                                | 117.1             | N/A                               |
| 2014 | N/A                | 30.79                            | 304.77                               | 4.90                       | 8.8                                | 118.3             | N/A                               |
| 2015 | N/A                | 31.26                            | 336.02                               | 4.70                       | 8.5                                | 119.4             | N/A                               |

In Table 5-3, the key results are presented for the case of a phased mandatory implementation scenario. In this figure, the shaded area indicates the ‘phase-in’ period, beginning in 2003 and ending in 2006, the year the FCC has specified as a target date for 85% household penetration. Under this scenario, the penetration in 2006 will be 65% and the FCC’s penetration goal will not be achieved until 2007. Similarly, the penetration rates in 2008 and later are not calculated in the table due to multiple DTV sales to one household may start since then.

#### **5.4 Integrated HighEnd Model DTV**

In this section, the integrated DTV analysis is presented for a HighEnd model (i.e. Case B in figure 2-3) SDTV. Rather than repeat the analysis of the previous section for a leader model TV, we note that the incremental costs and prices of a HighEnd SDTV can be estimated by simple adjustments to the previous section.

For the purpose of this analysis, we assume that a typical HighEnd SDTV would include a number of the DTV components shown in the Figure 3-3 block diagram of a DTV. Since these components are already included in the basic cost (and price) of the set, they are not counted as incremental costs to the end consumer to enable fully compatible ATSC reception.

A HighEnd TV would normally be a most expensive model with a larger screen size and might, for example, include internal digital signal processing to add such features as: picture-in-picture, line doubling resolution enhancement, and noise averaging. In order to implement such features, a HighEnd TV would require analog to digital to analog signal conversion and processing as well as significant memory for frame storage and buffering. With reference to the several cost estimates shown in this report (for example, see the Table 4-4 Summary costs provided by

Thomson), we roughly estimate that half of the total costs of implementation of ATSC compatibility is already included in a HighEnd TV.

However, the markups between direct material costs to factory prices and retail prices are different for a HighEnd TV versus a leader model TV. As previously indicated, while a typical markup between costs and manufacturer prices for a leader model are on the order of 1.5X, the markup for a HighEnd TV would be more on the order of 2.0X to 2.5X. Furthermore, while the retail margins for a leader set might be on the order of 20%, the retail margin for a HighEnd set would be in the vicinity of 35%. This leads to the following adjustments between the leader model and the high-end set incremental costs and prices.

For a High-end set:

- $HE_{dm} = \bullet LM_{dm} \times 0.5$  (High-end set has 50% of the incremental direct material cost as that of a leader model)
- $HE_{mp} = \bullet HE_{dm} \times 2.5$  (Markup of 2.5X for manufacturer prices on a high-end TV receiver)
- $HE_{rp} = \bullet HE_{mp} \times 1.35$  (Markup of 1.35X for retail prices on a high-end TV receiver)

$$\text{Or } \bullet HE_{rp} = 1.69 \times \bullet LM_{dm};$$

For a leader model:

- $LM_{mp} = \bullet LM_{dm} \times 1.5$  (Markup of 1.5X on manufacturer prices of a leader model receiver)
- $LM_{rp} = \bullet LM_{mp} \times 1.20$  (Mark up of 1.2X on retail prices of a leader model)

$$\text{Or } \bullet LM_{rp} = 1.8 \times \bullet LM_{dm}$$

Where:

- $LM_{dm}$  = the incremental direct material costs to add standard definition DTV capability to a leader model TV receiver
- $LM_{mp}$  = the incremental manufacturer prices to add standard definition DTV capability to a leader model TV receiver
- $LM_{rp}$  = the incremental retail prices to add standard definition DTV capability to a leader model TV receiver
- $HE_{dm}$  = the incremental direct material costs to add standard definition DTV capability to a high-end TV receiver
- $HE_{mp}$  = the incremental manufacturer prices to add standard definition DTV capability to a high-end TV receiver
- $HE_{rp}$  = the incremental retail prices to add standard definition DTV capability to a high-end TV receiver

The incremental manufacturing cost, incremental manufacturer price and incremental retail price ratios between a high-end set and a leader model are summarized as follows:

- $HE_{dm} = 50\% \times LM_{dm}$
- $HE_{mp} = 83\% \times LM_{mp}$
- $HE_{rp} = 94\% \times LM_{rp}$

## **5.5 Set-top box**

With over 100 million TV households and an average of 2.5 television sets per household, there are currently over 250 million analog televisions in the US. Based on the sales projections of integrated DTVs, many of these sets will not be replaced for 10 or more years. In fact, even under the most optimistic DTV penetration scenario, there might still be 100 million analog televisions in use by 2010.

Consumers are likely to extend the life of many of these sets by attaching a “transverter” or a set-top-box that enables a standard NTSC analog television to receive and view DTV. It is assumed that the typical transverter will be capable of receiving all 18 modes of DTV and will convert whatever mode received to SDTV 480I. The typical transverter may also be capable of receiving and converting “basic” (i.e. non-scrambled) digital cable channels thus it will be “cable-ready”. This typical configuration will serve as our “reference” design in this analysis

### **5.5.1 Market Projection for Transverters**

There are two cases under which a consumer might consider the purchase of a transverter:

- To extend the useful life of an otherwise good analog NTSC television; and,
- When purchasing a new television, and a package consisting of a new analog television plus a transverter is more cost effective or better suits the consumers needs than any integrated DTV. (This would probably only be the case if the consumer were forced to consider a higher-end model as their first-choice model is not available with an integrated DTV receiver).

The existence and size of both of these market segments are dependent upon the cost of a transverter relative to that of an integrated DTV. In the former case, the consumer will compare the cost of adding a transverter to that of a replacement integrated DTV television. In the latter case, the consumer will consider the convenience of an integrated set (and other incremental features) to the cost differential between an integrated DTV set and a transverter/TV package. In the event the FCC issues a mandate to include a digital receiver in all televisions above a certain size, the consumer in the market for a new TV that falls under the mandate will not have the option of a transverter/TV package.

### ***5.5.2 Digital Satellite Set top box costs***

In 1994, DirecTV began offering digital satellite service. At that time RCA Thomson was the only supplier of the DirecTV set top box which sold retail for \$799 per set. Today there are many suppliers of DirecTV boxes offering many models from the most basic to HDTV boxes that also receive terrestrial HDTV signals and boxes with integral PVR features.

Since the inception of digital direct-to-home (DTH) satellite television in the United States in 1994, the number of subscribers has grown to approximately 16 million as of today. With churn currently at approximately 0.7% per month, and assuming that only a small portion of those set-top-boxes are reused, the cumulative number of boxes manufactured for DirecTV and Echostar stands at approximately 21 million. Add to this, the boxes manufactured for Primestar and Alphastar, the total is in the range of 25 million.

Based on a learning curve factor of 75% (or 25% cost reduction) for each cumulative doubling of volume, the current retail price of a DTH set-top-box should be approximately \$170. Since DirecTV, Echostar and Primestar each use different approaches to signal transmission, it is possible that the learning factor would be lower. Much of the technological content of these boxes is, however, common with boxes manufactured for non-US DTH systems and other electronic devices. For example, MPEG chip sets, synthesized tuners, smart cards and smart card readers, remote controls, modulators, etc. are common among all DTH set-top-boxes. MPEG chip sets are found in many other consumer products such as DVB players, digital video recorders and personal computers. And remote controls are found today on stereos, air conditioners, fans, lighting systems, alarms, etc. These components are reaching significantly higher manufacturing volumes from application to other consumer electronic appliances, further lowering the manufacturing cost of DTH set-top boxes. Additionally, it is reasonable to expect that the manufacturing and retail markups have decreased due to significant competition.

Currently the unsubsidized retail cost of DTH boxes range from over \$400 down to a low of \$79, with the most popular models averaging around \$150 (based on a simple survey of prices conducted by ADL). These prices are in general agreement with the learning curve theory offered previously.

### ***5.5.3 Set top box costs***

Many of the major components that make up a typical transverter design are essentially the same as those found in DTH satellite set-top-boxes, integrated DTVs and other consumer electronics devices. Figure 5-20 below illustrates the major components that are present (shaded areas) in a satellite STB, a transverter and a DTV receiver. From this, it can be seen that large portions of the design and content are common across these devices.

Figure 5-20 Common Components across DTV Products

| Component          | Satellite STB | Transverter | Integrated DTV* |
|--------------------|---------------|-------------|-----------------|
| MPEG decoder       | Shaded        | Shaded      | Shaded          |
| MPEG Multiplexer   | Shaded        | Shaded      | Shaded          |
| RF Modulator       | Shaded        | Shaded      | White           |
| Remote Control     | Shaded        | Shaded      | White           |
| Housing            | Shaded        | Shaded      | White           |
| Power supply       | Shaded        | Shaded      | White           |
| Synthesized Tuner  | Shaded        | Shaded      | White           |
| Smart card         | Shaded        | White       | White           |
| Smart card reader  | Shaded        | White       | White           |
| Conditional Access | Shaded        | White       | White           |
| Antenna            | Shaded        | White       | White           |
| LNB                | Shaded        | White       | White           |
| QPSK demodulator   | White         | Shaded      | Shaded          |
| 8-VSB demodulator  | White         | Shaded      | White           |
| QAM demodulator    | White         | Shaded      | White           |
| Echo Canceling     | White         | Shaded      | Shaded          |

\* Considering only those additional components needed to add DTV to an analog design.

That is, in comparison to a satellite STB, the transverter does not include an antenna (although a special antenna may be required to receive terrestrial DTV, it is unlikely to be bundled with the transverter as is the case with a DTH receiver), LNB, smart card or conditional access components. It does require additional signal processing for echo or ghost canceling. The latter is also required in the integrated DTV receiver and is handled largely in semiconductors designed specifically for that application.

Analog NTSC addressable cable set-top boxes currently cost approximately \$100 and we anticipate that expect that they will remain at this price point throughout the study period. Given the technological content of the analog set-top box it is reasonable to assume that inclusion of a DTV receiver will initially cost \$100 and that this incremental cost will fall relative to the same manufacturing learning curve associated with DTV sets. That is, given the technological similarities between SDTV set-top transverter, digital satellite Set-top boxes, and DTV receivers, the set-top transverter is expected to benefit from the same manufacturing volumes and learning curve, associated with these other products. Therefore, the cost of a transverter is expected fall in relation to that of the integrated DTV receivers. The SDTV set-top transverter total cost and retail price decline is shown in .

Applying this approach, the initial cost of a set-top transverter is expected to be in the range of \$200 in 2001 (\$100 for an analog cable set-top box and an additional \$100 to incorporate a DTV receiver) leading to a manufacturing price of \$300 (1.5 times manufacturer's markup) and a retail price of \$360 (1.2 times retailer's markup). As in DTV receiver free market adoption baseline scenario, the cost of a set-top transverter would be expected to decline following the same learning curve shown in Figure 5-7. So that, by 2006, for example, the total costs would decline to \$121 (i.e. \$100 per set-top box plus \$21 for the DTV reception additional cost by 2006

based on Figure 5-7). This would result in a manufacturing price of \$182 (1.5 times total cost of \$121) and retail prices of \$218 (1.2 times \$182) by 2006.

Under the FCC mandate scenarios however, the total cost of a transverter could be dropped to as low as \$108.4 (i.e. \$100 for an analog set-top box and \$8.4 for a digital receiver) by 2006. This will lead to a manufacturing price of \$162.6 and retail price of \$195.

This estimate of \$218 by 2006 for a set-top transverter is somewhat higher than today's \$150 for a mature digital DTH satellite STB. For the reasons explained above, we would expect that the actual costs would likely fall somewhere between these two alternative means of estimation of retail prices.

## 6 Conclusions

### 6.1 Summary of Results

The above analysis in Section 5 above has estimated the unit sales for digitally enabled television under three scenarios. These results are summarized in Figure 6-1 and Figure 6-2.

Figure 6-1 Estimated DTV Cumulative Sales under Study Scenarios

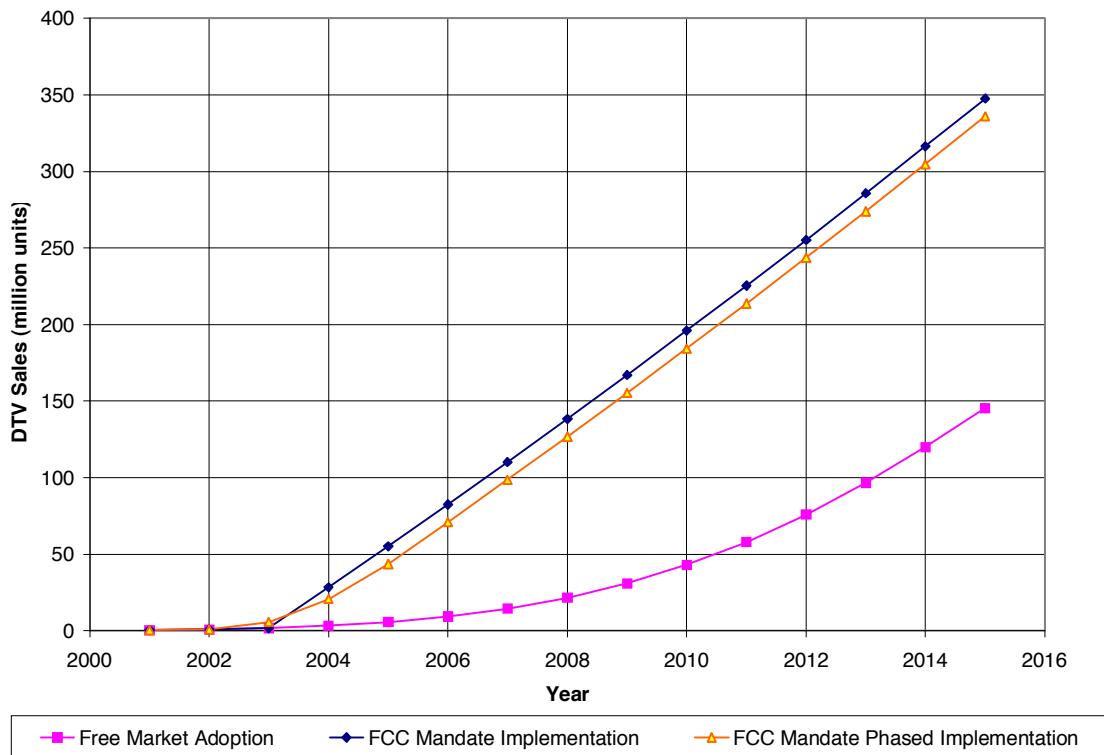



**Figure 6-2 DTV Market Penetration Rate Under Study Scenario**

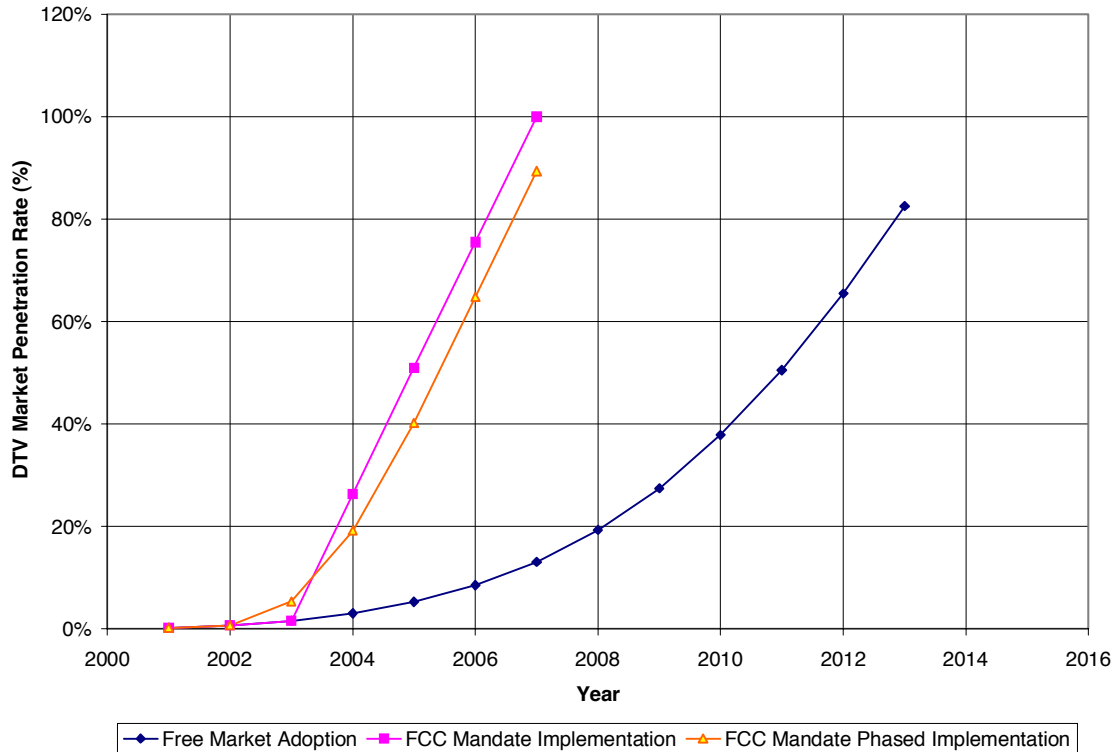

We have also compared DTV market penetration under the Bass Adoption baseline scenario with the adjusted forecast numbers from CEA [CEA, 2001a] for the next 6 years as shown in Figure 6-3. We obtained the CEA adjusted integrated DTV sales forecast by applying 20% on the CEA projected DTV sets and display sales. (Note: Twenty-percent (20%) is the ratio of integrated DTV sales over the CEA forecasted DTV sets and display sales numbers. [CEA, 2001d]) (As shown in Figure 4-1). The two forecasts are in general agreement especially in the initial 3 years with the CEA adjusted forecasts a little bit higher. Since 2003, the Bass Adoption projection exceeds the CEA adjusted numbers with 2.6 million sets higher in 2006. The major differences between these two forecasts are believed to be related to different forecast methodologies and assumptions applied.

**Figure 6-3 Bass Adoption Baseline Case Forecast and CEA Forecast DTV Penetration Comparison**

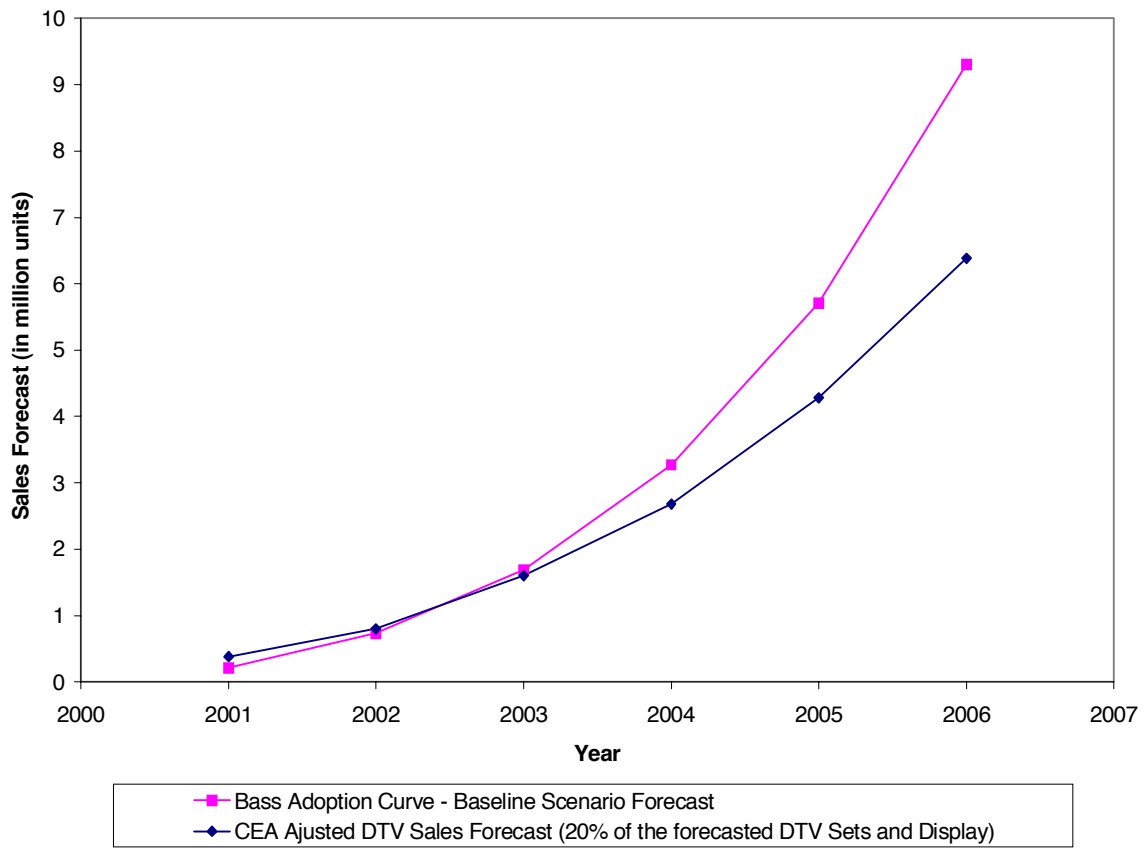
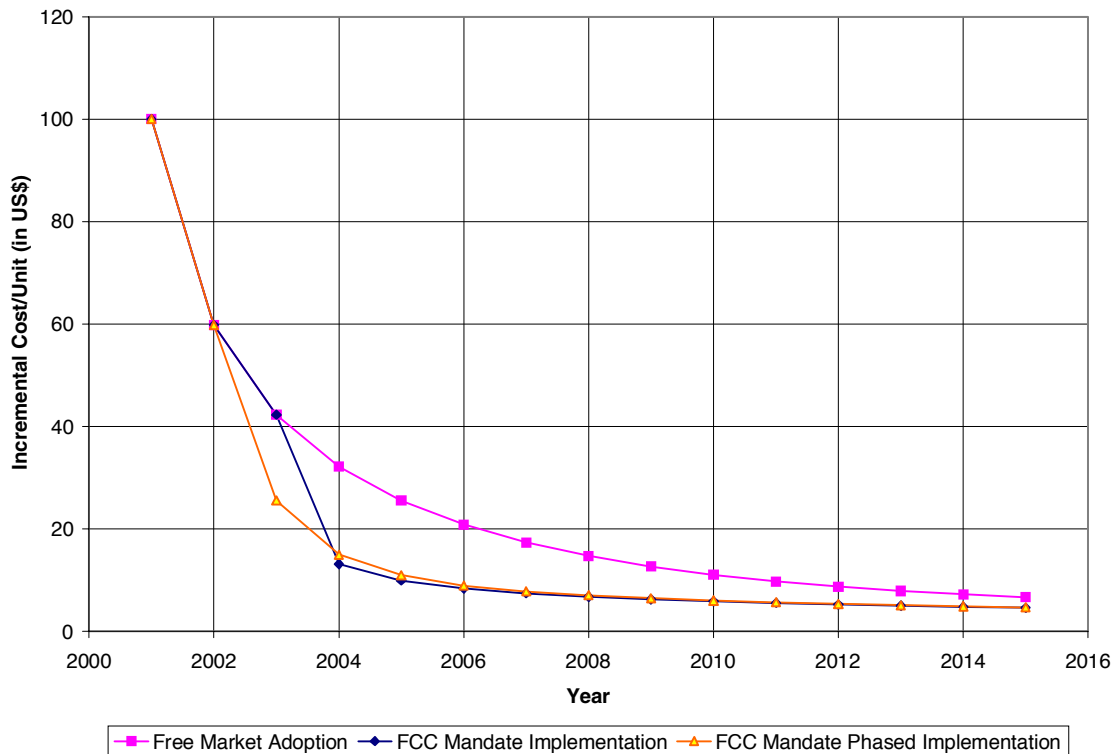

Figure 6-4 presents the corresponding cost-impact curves for each of the three study scenarios.

Figure 6-4 Incremental Cost Impact under Study Scenarios



## 6.2 DTV Market Penetration

Based on the above analysis, a number of observations and conclusions may be reached:

- **Free Market Adoption Scenario** - Assuming free market adoption without governmental influence, cumulative DTV sales are projected to grow to approximately 9.3 million units by 2006. The corresponding penetration is projected to reach only 8.5% by 2006 (assuming 109.3 million TV households [Carmel Group, 2001a] in 2006, and that each DTV sale represents a new adopting household). This is well below the FCC target of 85% by this date. According to these projections, the FCC penetration target would not be reached until 2014 or later in this baseline scenario.
- **FCC Mandate Scenario** - Assuming the FCC were to institute a full government mandate beginning 2004, cumulative DTV sales are projected to increase substantially relative to the baseline scenario. According to our projections, DTV sales would grow to approximately 82.5 million units by 2006. This implies that 75.5% of US households would have DTV reception capability by 2006. The FCC target of 85% penetration could be reached in 2007 under this scenario.

- Phased Mandate Scenario - Assuming the FCC were to require a phased introduction beginning in 2003, cumulative sales are projected to reach approximately 71 million by 2006, with a corresponding 65% DTV penetration by 2006. The 85% FCC target penetration rate could be reached in 2007 under this scenario.

### **6.3 Manufacturing Learning Curve**

Impact of the manufacturing “Learning Curve” on the incremental cost to manufacture DTV capable receivers as well as on the retail price to consumers has been examined. That is, as the cumulative number of manufactured units increases, the cost to manufacture these products falls exponentially due to the availability and decreasing cost of integrated components and improvements in manufacturing processes.

Under all scenarios, the incremental material cost will be approximately \$100 initially in 2001. Adjusted for typical manufacturing and retail markups, this corresponds to a \$180 retail price increase in a leader model television set to the consumer.

Specifically:

- Under the free market adoption (baseline) scenario, the incremental material cost to enable DTV reception is projected to gradually decrease from \$100 to approximately \$21 by the year 2006. Adjusted to reflect typical manufacturing and retail markups, the incremental price to consumers is projected to decrease from \$180 initially to \$38 by 2006.
- Under the mandate scenario, the incremental material cost is projected to decrease more rapidly due to increased DTV sales beyond 2004. The \$100 incremental material cost is projected to decrease to approximately \$8.4 by 2006, which corresponds to a projected retail price increase of approximately \$15.
- Under the mandatory phased implementation, the incremental material cost is projected to decrease from an initial \$100 to \$9 by 2006. The corresponding incremental retail price is estimated to be \$16.

### **6.4 Summary of Cost/Price Analysis**

#### **6.4.1 SDTV Receivers**

This analysis focused on four study “cases” consisting of two market segments – “market leader” televisions and “high-end” televisions, under two scenarios – “FCC mandate” and “free market” adoption (See Figure 3-1).

The results of the cost/price analysis over time for each of these cases are summarized in . As can be seen, the government mandate scenario will bring down the costs to customers more

rapidly, which is due to increased unit sales and greater manufacturing efficiencies. This applies to both leader models and high-end sets. High-end models typically require about half of the incremental cost to add a DTV receiver as compared to a leader (low-end) TV set, since high-end sets already include some internal digital signal processing and memory components to support such features as picture-in-picture, line doubling resolution enhancement, etc. On the other hand, high-end sets normally have a higher manufacturer price markup (2.5X the direct material cost compared to 1.5X for the leader models) and a higher retail profit margin (30% compared to 20%, respectively). This translates to the incremental retail price for a high-end model of approximately 94% of the retail price increase for a leader model.

As an example, the incremental direct material cost and corresponding retail price increase to incorporate a DTV receiver for a low-end set in 2001 is \$100 and \$180 respectively, and will decline to \$21 and \$38 respectively by 2006 under the free market rollout scenario. The comparable incremental cost and price for a high-end model is therefore around \$50 in incremental material cost and \$169 in retail price increase in 2001, expected to fall to \$11 and \$35 by 2006.

Figure 6-5 SDTV Receiver Cost/Price Analysis

**Case A: Leader**

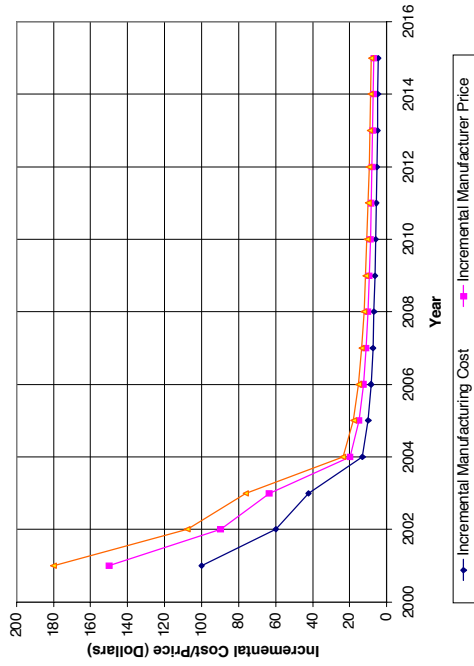

**Case 1:**  
Government  
Mandates  
100% DTU

**Case B: HighEnd**

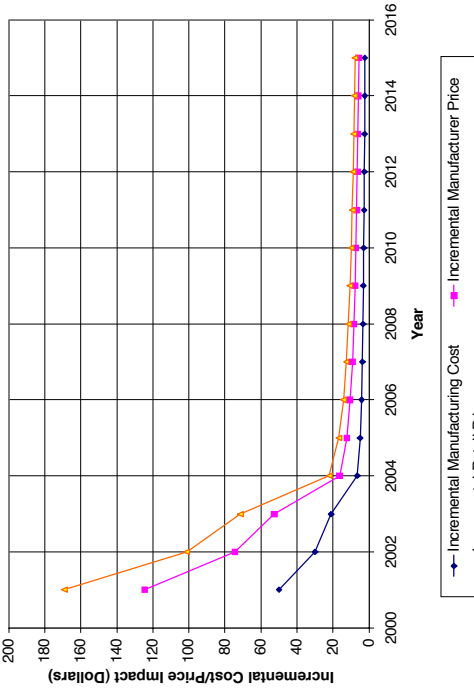

**Case 2:**  
Marketplace  
Decides  
Volume  
Rollout

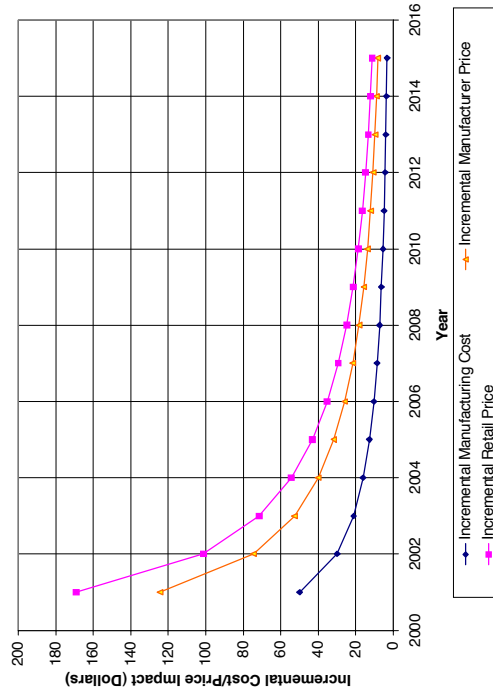
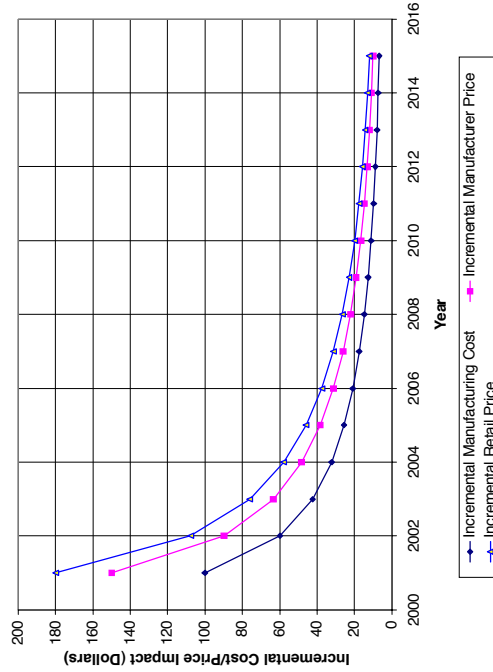

### **6.4.2 Set-top Transverter**

The manufacturing cost and retail price of set-top transverters were also assessed. These devices enable existing analog TVs to receive digital ATSC television.

The SDTV set-top transverter total cost and price decline is shown in . This is based on the current cost of an analog NTSC addressable cable set-top box (\$100 throughout the study period), plus the same \$100 incremental cost to add a digital receiver to a television (in year 2001). As described further in Section 5.5, “Set-top Box”, SDTV set-top transverters will also be subject to learning curve efficiencies and cost reductions in relation to the volume of other digital receiver products manufactured over time due to the similarities between SDTV set-top transverters, satellite Set-top boxes, and DTV receivers.

## **6.5 Major Uncertainties**

Recognizing that there is significant uncertainty in various model inputs and assumptions, it is important to realize that various factors can significantly affect the estimates presented in this report. Several key factors affecting the results include the following:

- ***Free market vs. Government Mandate of DTV Receivers***

The single factor with the greatest potential impact on DTV adoption that we now face is that of FCC policy yet to be defined relative to DTV. As can be seen from this analysis, the results based on the free market adoption scenario differ significantly from the results gained under the FCC mandated scenarios. That is, cumulative DTV sales, market penetration and the incremental cost to incorporate DTV receivers in newly manufactured sets, are all very sensitive to the course chosen by the FCC. This is the most important factor having the greatest potential impact on these factors.

- ***Price Elasticity and Market Adoption***

The purchasers of low-end (“leader”) TV sets are expected to be more price sensitive than buyers of more expensive, higher-end sets. Therefore, the sales projections of integrated DTVs in the initial years may be substantially lower due to price elasticity effects which have not been considered in this analysis.

That is, the initial \$180 retail price increase for the inclusion of a DTV receiver could substantially impact purchasing decisions regarding low-end sets. We learned from the interviews we conducted with a manager of a leading consumer electronics store, that “consumers of ‘leader’ sets are not likely to pay more than \$60 premium for inclusion of a digital receiver”.

The manufacturing cost learning curve suggests that the incremental retail price for inclusion of a digital receiver will not fall to \$60 until 2004 under the free market adoption case, and under the government mandate scenarios it will not reach \$60 until 2003.

Prior to this time, sales of low-end 'leader' models can only be explained by the behavior of 'early adopters' who will pay a significant premium to have the latest product advancements. There is a risk that sales in these early years will not reach the projected level. Changes in the cumulative sales would impact the manufacturing learning curve pushing the estimated cost reductions and sales projections further into the future.

- ***Forward Pricing***

Should the manufacturer adopt a Forward Pricing strategy, the retail prices may be dramatically lower in the initial years of introduction. This approach could significantly fuel a more rapid acceptance and adoption of DTV receivers than indicated by our projections, resulting in faster cost reductions.



## 7 References

1992 Cable Act: Congress enacted the 1992 Cable Act, which among other things, required the FCC to address cable/TV compatibility from the consumers public interest viewpoint. 1992

47 C.F.R. § 73.624 Digital television broadcast stations, Section (d), 10/1/2000

47 U.S.C. §309 (j) (14), “Auction of Recaptured Broadcast Television Spectrum”, 2000a

47 U.S.C. §§534, 535, “Carriage of Local Commercial Television Signals”, “Carriage of Non-commercial Educated Television”, 2000b

47 U.S.C. §73.624(d), 2000c

ATI, News Release, 1/2000

Bass, Frank M, “A New Product Growth Model for Consumer Durables,” Management Science, 15 January, 1969

Broadcom: Company News Release, 10/2000

Cahner In-Stat: HDTV: “What is Going Wrong (Technology Information)”, Electronic News (1991), January 1, 2001

Carmel Group: “US Personal TV Subscriber Forecast”, DBS Investor, May 2001a

Carmel Group: “US Analog/Digital TV Set-top Receiver Forecast”, “Digital DBS Systems’ Subscribers: From Day One Until Today”, DBS Investor, June, 2001b

Conexant, News Release, 9/1999

Consumer Electronics Association (CEA): “Digital Television Gains Momentum, Consumers Are Ready for DTV”, DigitalAmerica 2001, US Consumer Electronics Industry Today, 2001a

CEA: “Direct-View Color TV Receivers, Digital TV sets and Displays, VCR Decks, TV/VCR Combinations, Personal Computers”, CEA Market Research, 1996 – 2001 US Consumer Electronics Sales and Forecast, January 2001b

CEA: “Digital TV Set Top Decoders”, DTVGuide, May 2001c

CEA: “CE Future Interactive Forecast Database”, eBrain Market Research, 11/2000a

CEA: shows 69 "Stations Broadcasting Digital Signal" (page 22, DTV Guide, January 2000) that in the top 30 TV markets there is a good chance that at least one broadcaster offers a DTV

signal. The same document also references DTV and HDTV programming available via digital cable TV and also via direct broadcast satellite (DBS) TV, 1/2000b

CEA: Transcript of Conference: “Transcript of Conference: Is Laissez-Faire Fair?”, July 24, 2001d

Federal Communications Commission (FCC): “Advanced Television Systems and their Impact Upon the Existing Television Broadcast Service”, Fifth Report and Order in MM Docket No. 87-268, Released on April 21, 1997

FCC: “Broadcast Signal Carriage Issues”, Report and Order in MM Docket No. 92-259, 8 FCC Rcd 2965, 2977-78, (“Must-Carry Order”), 1993a

FCC: “Broadcast Signal Carriage Issues, Memorandum Report and Order, 9 FCC Rcd 6723, (“Must-Carry Reconsideration”), 1994

FCC: “Comments of the Consumer Electronics Association”, MM Docket No. 00-39, April 6, 2001a

FCC: “Comments of Thomson Multimedia, Inc.”, §II.A.1, MM Docket No. 00-39, April 6, 2001b

FCC: “Implementation of the Cable Television Consumer Protection and Competition Act of 1992, Cable Home Wiring”, 8 FCC Rcd 1435, 1993b

FCC: “Review of the Commission’s Rules and Policies Affecting the Conversion to Digital Television”, §V.108, Appendix C, Report and Order and Further Notice of Proposed Rule Making, MM Docket No. 00-39, Released on January 19, 2001c

FCC: “Review of the Commission’s Rules and Policies Affecting the Conversion to Digital Television, §II.3”, Notice of Proposed Rule Making, MM Docket No. 00-39, Released on March 8, 2000

FCC: On 11/10/93, the FCC issued a Notice of Proposed Rule Making (NPRM) followed by a 4/4/94 report and order. The impact of this was to require that set-top converter/descramblers be unbundled with respect to signal protection/conditional access versus additional functions, and further that a decoder interface standard be created to allow setback devices that allow the consumer full use of remote controls and other internal functions of their consumer electronics equipment. The FCC order allowed for the continued ownership and cable operator provision of the signal protection portion of subscriber premise equipment. November 1993c

Genesis Microchip, News Release, 1/2001

Gruber, Harald, “The yield factor and the learning curve in semiconductor production”, Applied Economics, 8/1994

Hauppauge Digital Inc., News Release, 7/1999

Helsen, Kristiann; Jedidi, Kamel; and DeSarbo, Wayne S.; “A New Approach to Country Segmentation Utilizing Multinational Diffusion Patterns”, Journal of Marketing, 10/1993

iChip Technology, News Release, 12/2000

Japan High Tech Review, v7, n6, pN/A: “Japanese Chip Makers Keenly Watch American Moves”: “A ‘forward pricing’ concept: in the semiconductor business, as in many other manufacturing businesses, a maker usually comes up with a price in expectation of future cost reductions based on ‘learning curve’, under which the initial yield ratio will improve and ensuring mass production will lead to economics of scale.” June 1990.

Konka, News Release, 10/1999

Mitsubishi, News Release, 10/1998

MMDS or LLDS: Multichannel Multipoint Distribution Service (MMDS), Local Multipoint Distribution Service (LMDS). Both utilize microwave radio transmitters that are essentially ‘line-of-sight’ and basically differ only in the frequency and bandwidth spectrum utilized.

Motorola, News Release, 11/2000

MSTV, NAB: MSTV represents nearly 400 local television stations on technical issues relating to analog and digital television services. NAB serves and represents the American broadcast industry as a nonprofit incorporated association of radio and television stations and broadcast networks.

Nielsen Media Research, National Cable & Telecommunications Association, 5/2001

NxtWave Communications, News Release, 12/2000

Oren Semiconductor, News Release, 11/2000

Ovum: “DTV: How to survive and make money”, 9/1998

Paul Kagan Associates: “Kagan’s DBS Industry Projections 2000-2010”, Cable World, April 30, 2001

Philips Semiconductors, News Release, 4/1999

Samsung, News Release, 7/1999

Sarnoff, News Release, 11/1998

SkyTune, News Release, 7/1999

STMicroelectronics, News Release, Electronics Engineering Times, July, 2, 2001

Strategy Analytics: “HDTV Faces Long Haul Says Strategy Analytics”, PR Newswire, 3094, December 2, 1998

Takada, Hirokazu & Jain, Dipak, “Cross-National Analysis of Diffusion of Consumer Durable Goods in Pacific Rim Countries”, Journal of Marketing, 4/1991

TeraLogic, News Release, 11/2000

Texas Instrument, News Release, 12/2000

Trident, News Release, 11/1999

Tweeter Center, Summer 2001

US Census Bureau, American Housing Survey, 2000

Whitaker, Jerry/NAB: DTV The Revolution in Digital Video – “The ATSC DTV System”, Page 283

Zenith, News Release, 2/1993

## **APPENDICES**

## A. Supporting Data

This appendix provides key data employed in this analysis. The tables presented here represent the data supporting the plots presented in the main report and indicate the source of the data.

**Table A-1 U.S. Sales of Digital TV Sets and Displays to Dealers**

|                             | <b>US Digital TV Sets and Display* Sales Forecast</b> |             |             |             |             |             |             |             |             |
|-----------------------------|---|-------------|-------------|-------------|-------------|-------------|-------------|-------------|-------------|
| (in million sets)           | <u>1998</u>   | <u>1999</u> | <u>2000</u> | <u>2001</u> | <u>2002</u> | <u>2003</u> | <u>2004</u> | <u>2005</u> | <u>2006</u> |
| Annual Sales to Dealers     | 0.014   | 0.121       | 0.65        | 1.125       | 2.1         | 4           | 5.4         | 8           | 10.5        |
| Cumulative Sales to Dealers | 0.014   | 0.135       | 0.785       | 1.91        | 4.01        | 8.01        | 13.41       | 21.41       | 31.91       |

\* Includes direct-view and projection DTVs with integrated digital decoders and stand-alone DTV displays.  
 (Source: Consumer Electronics Association (CEA), 2001)

**Table A-2 U.S. HDTV Product Shipments**

|                   | <b>US HDTV Product Shipment</b> |             |             |             |             |
|-------------------|---------------------------------|-------------|-------------|-------------|-------------|
| (in million sets) | <u>2000</u>                     | <u>2001</u> | <u>2002</u> | <u>2003</u> | <u>2004</u> |
| Product Shipment  | 0.604                           | 1.865       | 3.71        | 6.04        | 9.975       |

(Source: Cahner In-Stat, 1/01)

**Table A-3 U.S. DTV Receiver Sales Forecast**

|                      | <b>US DTV Receiver Sales Forecasts</b> |             |             |             |             |             |             |             |
|----------------------|--|-------------|-------------|-------------|-------------|-------------|-------------|-------------|
| (in millions)        | <u>1998</u>                            | <u>1999</u> | <u>2000</u> | <u>2001</u> | <u>2002</u> | <u>2003</u> | <u>2004</u> | <u>2005</u> |
| Annual Shipments     | 0.05                                   | 0.13        | 0.29        | 0.47        | 0.75        | 1.2         | 1.7         | 2.4         |
| Cumulative Shipments | 0.05                                   | 0.18        | 0.47        | 0.94        | 1.69        | 2.89        | 4.59        | 6.99        |

(Source: Strategy Analytics, 12/98)

**Table A-4 U. S. Digital TV Subscribers**

|                                | <b>Digital TV Subscriber Forecast</b> |             |             |             |             |             |             |             |
|--------------------------------|---------------------------------------|-------------|-------------|-------------|-------------|-------------|-------------|-------------|
| (number of users, in millions) | <u>1998</u>                           | <u>1999</u> | <u>2000</u> | <u>2001</u> | <u>2002</u> | <u>2003</u> | <u>2004</u> | <u>2005</u> |
| DTV - Terrestrial Subs         | 0                                     | 1.492       | 3.506       | 5.213       | 7.181       | 8.34        | 8.991       | 9.454       |
| DTV - Cable                    | 0.012                                 | 1.273       | 3.031       | 5.347       | 8.298       | 11.935      | 16.361      | 21.869      |
| DTV - Satellite                | 6.552                                 | 8.256       | 10.042      | 11.778      | 13.39       | 14.825      | 16.08       | 17.207      |

(Source: Ovum Group, 9/98)

**Table A-5 U.S. VCR Sales**

|                  | <b>TOTAL VCR Sales to Dealers**</b> |             |             |             |             |             |             |             |             |  |
|------------------|-------------------------------------|-------------|-------------|-------------|-------------|-------------|-------------|-------------|-------------|--|
| (in millions)    | <u>1993</u>                         | <u>1994</u> | <u>1995</u> | <u>1996</u> | <u>1997</u> | <u>1998</u> | <u>1999</u> | <u>2000</u> | <u>2001</u> |  |
| Annual Sales     | 14.077                              | 15.104      | 15.767      | 17.84       | 18.984      | 21.26       | 27.227      | 29.014      | 26.885      |  |
| Cumulative Sales | 14.077                              | 29.181      | 44.948      | 62.788      | 81.772      | 103.032     | 130.259     | 159.273     | 186.158     |  |

\*\* Including VCR decks and TV/VCR Combinations.  
 Data Source: Consumer Electronics Association, 2001

**Table A-6 Sales of Color TV Receivers**

| Direct-view Color TV receivers                                      |        |        |        |        |        |        |        |        |        |
|---|--------|--------|--------|--------|--------|--------|--------|--------|--------|
| (in millions)   | 1993   | 1994   | 1995   | 1996   | 1997   | 1998   | 1999   | 2000   | 2001   |
| Annual Sales to Dealers<br>(1)                                      | 23.005 | 24.715 | 23.231 | 22.384 | 21.293 | 22.204 | 23.218 | 23.776 | 23.901 |
| Annual Color TV Sales<br>with Projection TV (2)                     | 23.470 | 25.351 | 24.051 | 23.271 | 22.210 | 23.274 | 24.450 | 25.236 | 25.121 |
| Annual Color TV Sales<br>with Projection TV and<br>TV/VCR Combo (3) | 25.099 | 27.368 | 26.256 | 25.470 | 24.521 | 26.421 | 28.868 | 30.245 | 30.401 |

(1) Excludes LCD, Projection TV, TV/VCR combinations  
(2) Data (1) plus Projection TV sales  
(3) Data (1) plus Projection TV and TV/VCR combination sales  
Data Source: Consumer Electronics Association, 2001

**Table A-7 U.S. Direct Broadcast Satellite Subscribers**

| DBS Subscribers        |       |       |       |       |       |        |        |      |      |      |      |      |      |      |      |
|------------------------|-------|-------|-------|-------|-------|--------|--------|------|------|------|------|------|------|------|------|
| (in millions)          | 1994  | 1995  | 1996  | 1997  | 1998  | 1999   | 2000   | 2001 | 2002 | 2003 | 2004 | 2005 | 2006 | 2007 | 2008 |
| <b>DBS Subscribers</b> | 0.587 | 2.273 | 4.425 | 6.421 | 8.866 | 11.440 | 14.896 | 18.2 | 20.8 | 23.1 | 25.1 | 26.9 | 28.5 | 29.9 | 31.2 |

Source: DBS Investor from the Carmel Group, May 2001

**Table A-8 U.S. Sales of Personal Computers**

| Personal Computers*** |       |        |        |        |        |        |        |        |         |
|-----------------------|-------|--------|--------|--------|--------|--------|--------|--------|---------|
| (in millions)         | 1993  | 1994   | 1995   | 1996   | 1997   | 1998   | 1999   | 2000   | 2001    |
| Annual Sales          | 5.85  | 6.73   | 8.40   | 9.40   | 11.00  | 12.80  | 14.90  | 16.40  | 17.50   |
| Cumulative Sales      | 5.850 | 12.575 | 20.975 | 30.375 | 41.375 | 54.175 | 69.075 | 85.475 | 102.975 |

\*\*\* Sales through consumer channels, includes notebooks, does not include TV/PC combinations, average price includes monitors  
Data Source: Consumer Electronics Association, 2001

**Table A-9 Average Price of U.S. Analog/Digital TV Set-top Receivers**

| US Analog/Digital TV Set-top Receivers - Average Unit Manufacturer Price |       |       |       |       |       |       |       |       |
|--|-------|-------|-------|-------|-------|-------|-------|-------|
|  | 1997  | 1998  | 1999  | 2000  | 2001  | 2002  | 2003  | 2004  |
| Analog Cable   | \$140 | \$135 | \$130 | \$125 | \$120 | \$115 | \$105 | \$105 |
| Digital Cable  | \$377 | \$335 | \$300 | \$265 | \$255 | \$270 | \$280 | \$280 |
| Digital Satellite  | \$225 | \$220 | \$190 | \$180 | \$175 | \$170 | \$160 | \$155 |
| Fixed Wireless Broadband   | \$500 | \$480 | \$455 | \$425 | \$400 | \$375 | \$350 | \$325 |
| TV/Internet Digital Converters (or DTV/PC Card)                          | \$235 | \$215 | \$175 | \$170 | \$165 | \$160 | \$155 | \$155 |

Source: The Carmel Group: DBS Investor, June 2001